

# Details and Load Tables for Stay-Form® the stay-in-place concrete form

Bulkheads  
Blindside Walls  
Grade Beams  
Pile Caps  
Footings  
Bridges

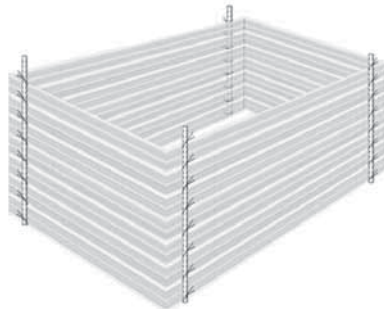

Tunnels  
Ductbanks  
Retaining Walls  
Keyways  
Column Pockets  
Shotcrete

THE DIAGRAMS PRESENTED IN THIS BOOKLET ARE TO DEMONSTRATE A SUGGESTED METHOD OF ASSEMBLY ONLY. SPACING DIMENSIONS AND FOOTING ANCHORS MAY VARY DEPENDING ON POUR RATES AND DEFLECTION SPEC. THE DIAGRAMS SHOULD NOT LIMIT NOR RESTRICT IDEAS OR KNOWLEDGE THE WORKMEN HAVE ABOUT FORMING METHODS OR TECHNIQUES.

THE ENCLOSED LOAD TABLES CAN BE USED AS A GUIDE WHERE DATA PRESENTED IN LOAD TABLES ARE APPLICABLE. IF DATA IN LOAD TABLES ARE NOT APPLICABLE, THEN A SEPARATE CALCULATION MUST BE MADE TO MEET YOUR REQUIRED SPEC. ALL FORMING METHODS, HOWEVER, MUST COMPLY WITH AMICO'S PUBLISHED LOAD TABLES, OR SEPARATE CALCULATION.

ALABAMA METAL INDUSTRIES CORPORATION  
3245 Fayette Avenue ♦ Birmingham, AL 35208

[www.amico-online.com](http://www.amico-online.com)

A GIBRALTAR INDUSTRIES COMPANY



QUALITY PRODUCTS - COAST TO COAST

Technical Support  
[stayform@gibraltar1.com](mailto:stayform@gibraltar1.com)

Sales Department  
800/366-2642

## TABLE OF CONTENTS

TABLE OF CONTENTS		
TECHNICAL DATA	GUIDELINES FOR LOADING	1
	Stay-form® #66 DIMENSIONS	2
	Stay-Form® #66 DIMENSIONS - Metric	3
	INSTALLATION LAP DETAIL	4
	PHYSICAL PROPERTIES OF Stay-form® #66	4
BULKHEADS	REBAR PENETRATION OF BULKHEADS	5
	FORMING HEAVY MAT BULKHEAD	6
	FORMING HEAVY MAT BULKHEAD WITH KEYWAY	7
	FORMING HEAVY MAT BULKHEAD WITH WATERSTOP	8
	FORMING HEAVY MAT BULKHEAD WITH KEYWAY AND WATERSTOP	9
	FORMING WALL BULKHEAD WITH KEYWAY WITH LUMBER	10
	FORMING WALL BULKHEAD WITH KEYWAY WITH REBAR	11
	FORMING WALL BULKHEAD WITH KEYWAY AND WATERSTOP – PLAN VIEW	12
	FORMING WALL BULKHEAD WITH KEYWAY AND WATERSTOP – SECTION VIEW	13
	FORMING WALL BULKHEAD WITH WATERSTOP WITH REBAR	14
BLINDSIDE WALLS	BLINDSIDE WALLS	15
GRADE BEAMS	FORMING GRADE BEAMS, FOOTINGS AND MAT SLABS	16
	GRADE BEAM FORMWORK	17
	FORMING BLOCK-OUTS WITH REBAR	18
	FORMING BLOCK-OUTS WITH LUMBER	19
PILE CAPS	FORMING PILE CAPS	20
FOOTINGS	FORMING FOOTINGS	21
DUCTBANKS	FORMING DUCTBANKS	22
MISCELLANEOUS APPLICATIONS	FORMING BEAM WITH KEYWAY	23
	PAN JOIST CONSTRUCTION JOINT	24
	FORMING ON GRADE SLOPED SLAB	25
	FORMING BOX BEAM CAVITIES	26
	FORMING SLAB POCKET	27
	FORMING CONCRETE COLUMNS	28
	UNDER WATER PILING REPAIR	29
FORMING FLOOD WALLS	30	



**GUIDE LINES FOR LOADING #66 Stay-Form®**  
Support Spacing (Running Perpendicular to Stay-form Ribs)

Support Spacing on centers (inches)	24"	18"	12"
Lateral Loading (psf)	1200	1200	1600
Liquid Head (feet)	8.0	8.0	10.0
Pour Rate (feet/hour)	4.0	4.0	7.0
Maximum Deflection (in)	1-1/4	3/4	1/8
Recommended Lap (inches vertically)	8	6	4
Recommended Ties at Lap (both ribs horizontally)	2	2	1

THE LOADING SPECIFICATIONS ABOVE ARE BASED ON THE FOLLOWING CONDITIONS:

General Construction

1. When using tie wire to secure Stay-Form to bracing use 16GA wire and tie each rib to bracing member.
2. When using staples or nails; each rib shall be attached to the wooden support.
3. When joining sheets end to end, allow for a minimum lap of 4-8 inches over each sheet. Laps should occur over a support with both adjoining sheets secured with wire ties, staples or sheet metal screws.
4. Vertically stacked Stay-Form sheets require a minimum 2-rib lap of each adjoining sheet. Nest sheets into the other; secure with wire ties, staples or sheet metal screws at a maximum spacing of 24-inches on center. See detail on page 4.
5. When possible place Stay-Form with ribs facing away from supports and into the concrete pour.
6. Back-fill 90% of grade beam, footing, or pile cap height prior to concrete pour as an alternative to external bracing.
7. "V" notch 80 percent through Stay-Form ribs to make 90 degree turns.

Blindside Walls

8. Do not vibrate previous lift by more than 6-inches.
9. Stay-Form can accommodate a pour rate of 4-7 feet per hour.
10. Stay-Form is compatible with self-consolidating concrete.
11. Stay-Form can be cut with a hand held grinder, cutoff saw, abrasive blade or tin snips.

The AMICO rule of thumb is to "brace Stay-Form like you would a piece of plywood." The location, size and spacing of rebar or wooden bracing is similar to that for conventional forming methods per ACI 347, Guide to Formwork for Concrete.

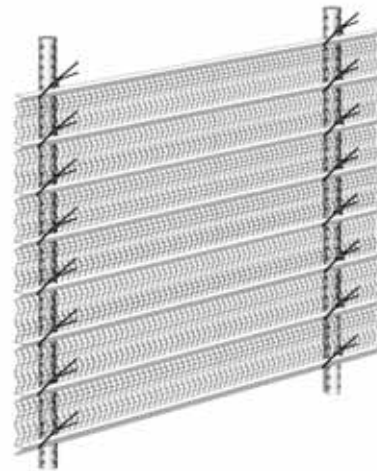

Stay-Form sheets can be either wire tied to rebar (as illustrated above) or nailed / stapled to wooden supports (as illustrated below) depending upon the type of forming required or availability of materials.

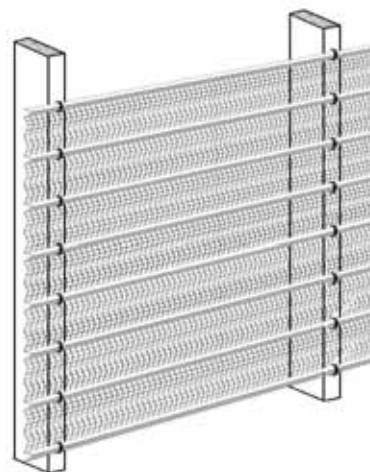

### Stay-Form® #66 DIMENSIONS

Stay-Form #66 - 26 Gauge  
Weight 11.9 lbs. per sheet  
V-Ribs 8-each at 3/4" deep and 3 7/8" on center  
Sheet Size\* 27" wide\* x 96" long\* (18 sq. ft. per sheet)  
Pallet Size 250 sheets per pallet (4500 sq. ft.)  
Bundle Size 5 sheets (90 sq. ft.)

Sheet Length  
96-inches -0 + 1/2-inch

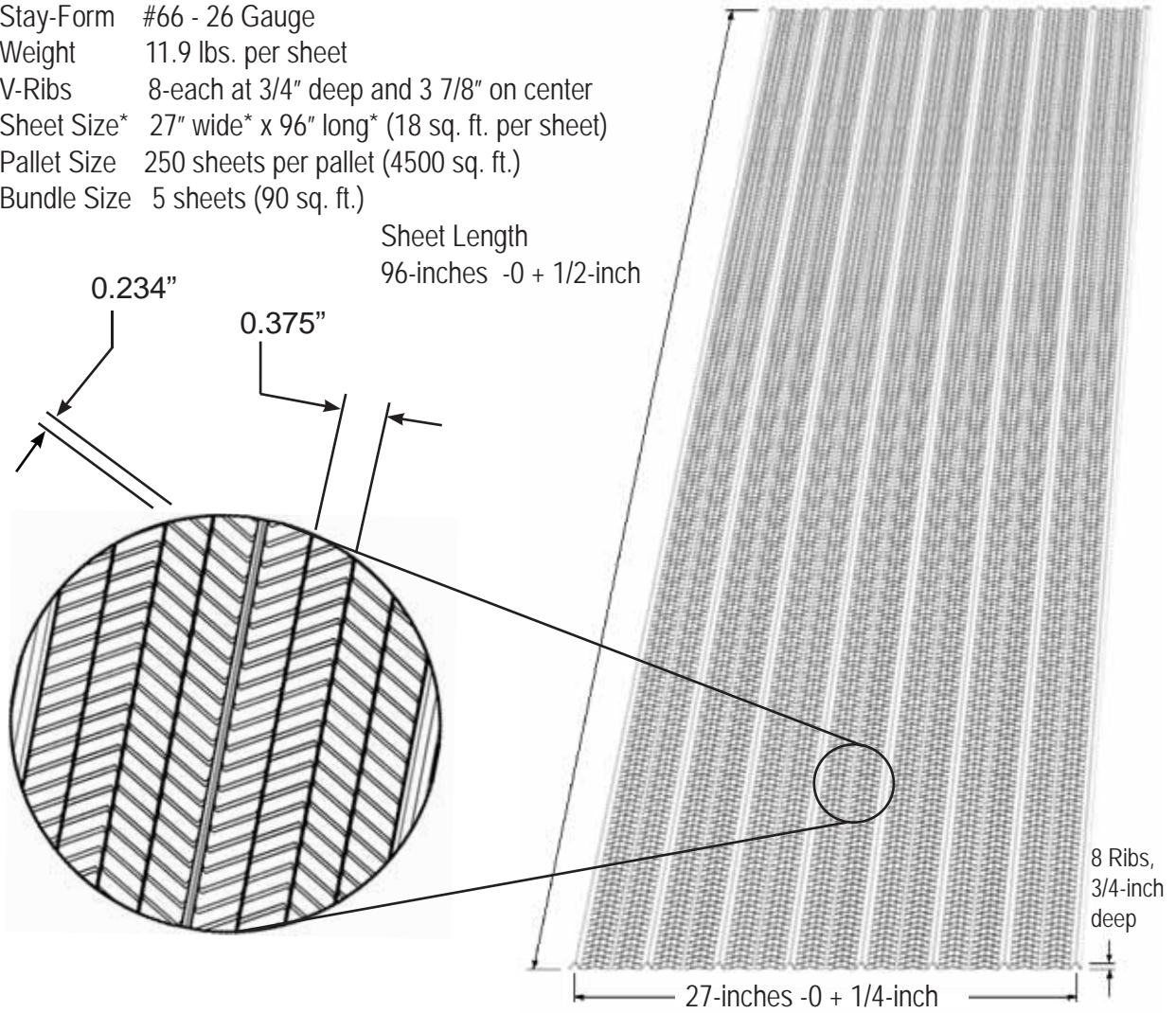

7 spaces @ 3-7/8-inches each = 27- inches

Special Order - 10-foot and 12-foot lengths are also available. Call for lead-time.

NOTE: See load table on page 3 for spacing and load information.

### Stay-Form® #66 Dimensions - METRIC

Stay-Form #66 - 26 Gauge  
Weight 5.4kg per sheet  
V-Ribs 8-each at 19.1mm deep and 98.4mm on center  
Sheet Size 686mm wide\* x 2438mm long\* (1.67 m<sup>2</sup> per sheet)  
Pallet Size 250 sheets per pallet 417.5m<sup>2</sup>  
Bundle Size 5 sheets (37.43 sq. m)

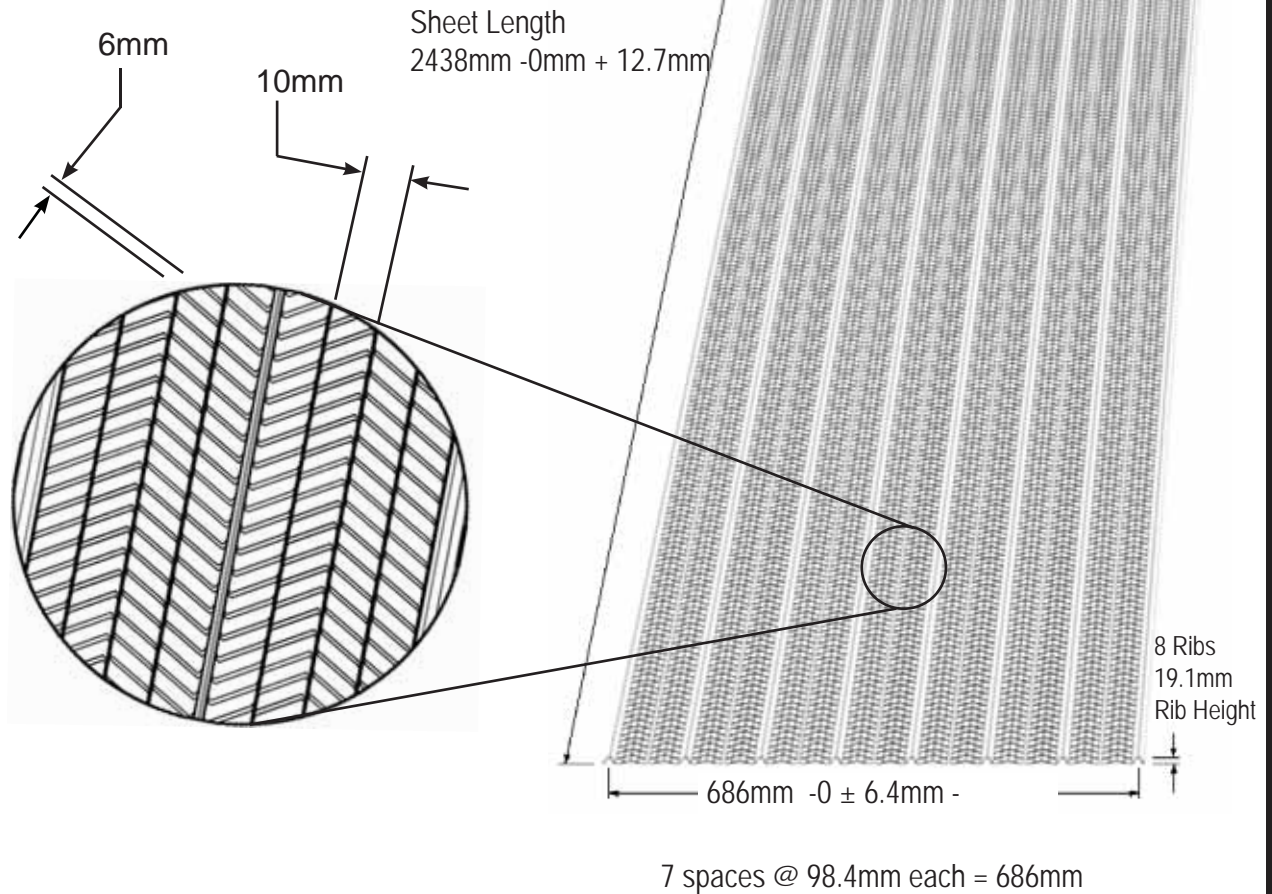

Special Order - 10-foot and 12-foot lengths are also available. Call for lead-time.

NOTE: See load table on page 3 for spacing and load information.

### INSTALLATION LAP DETAIL

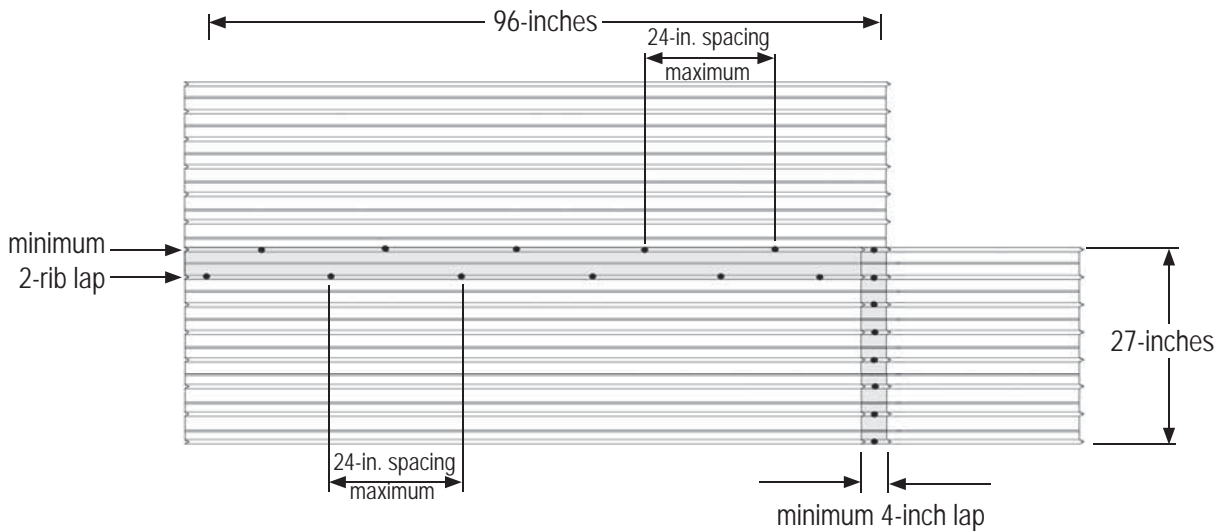

### PHYSICAL PROPERTIES OF Stay-form® #66

Gauge Thickness	26 Gauge
Galvanized Sheet Thickness	0.0217 in. (0.5512mm)
Sheet Width	27-inches (686mm)
Sheet Length - Standard	96-inches (2438mm)
Sheet Length - Special Order	10-feet (3.489m) and 12-feet (3.658m)
Weight per Square Foot	0.66 lbs/ft <sup>2</sup> (3.22 kg/m <sup>2</sup> )
Yield Strength	27.63 ksi (190.50 MPa)
Yield Strain	0.00297
Ultimate Strength	50.28 ksi (346.68 MPa)
Ultimate Strain	0.25
Modulus of Elasticity (E)	29,500 ksi (203,400 MPa)
Stay-Form® is manufactured from hot dip galvanized steel to meet ASTM A-653.	

This data is based on results from testing conducted by an independent testing lab. For more information on the details of the testing, contact AMICO at 800/366-2642.

NOTE: See load table on page 3 for spacing and load information.



## REBAR PENETRATION OF BULKHEADS

### FORMING WITH REBAR

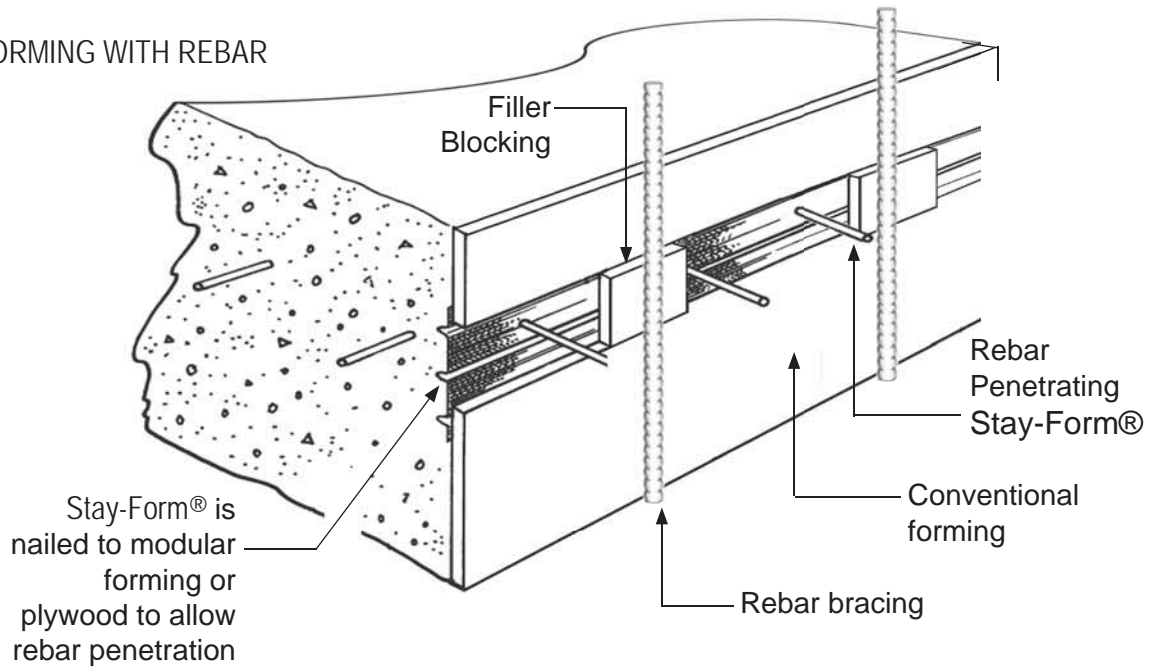

### FORMING WITH LUMBER

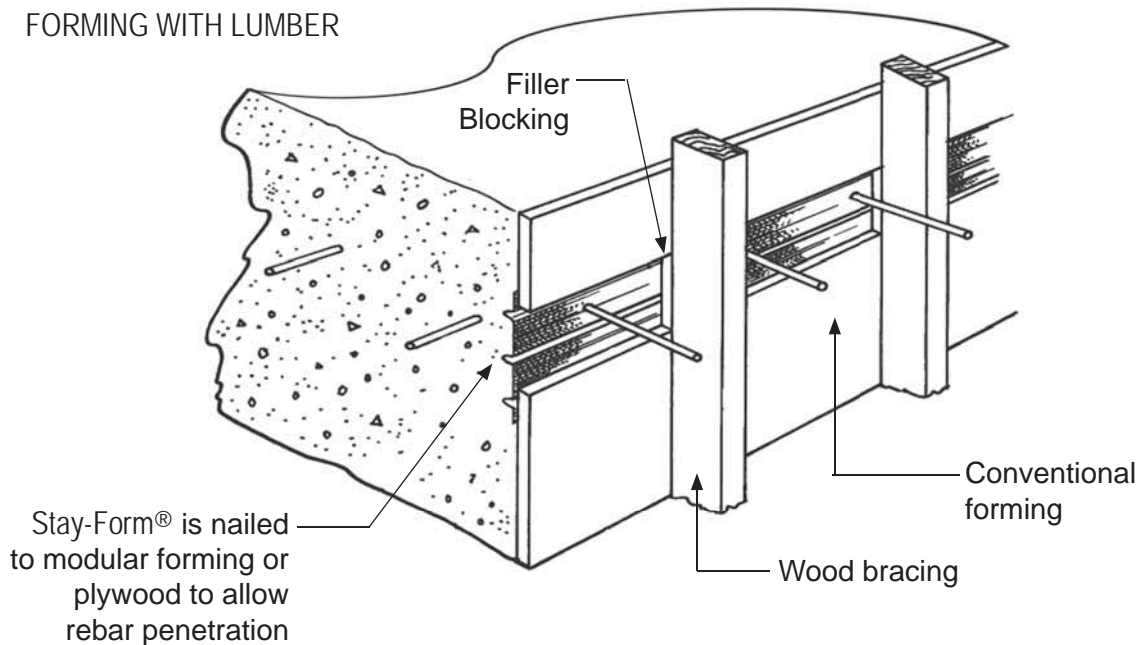

NOTE: See load table on page 3 for spacing and load information.

## FORMING HEAVY MAT BULKHEAD

### FORMING WITH REBAR

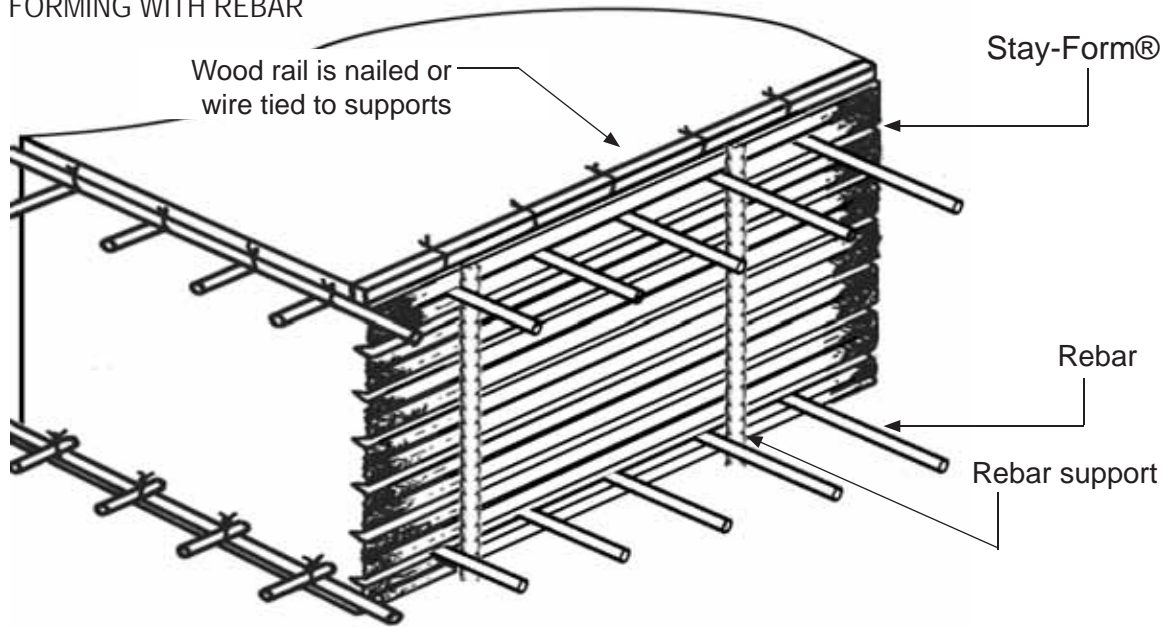

### FORMING WITH LUMBER

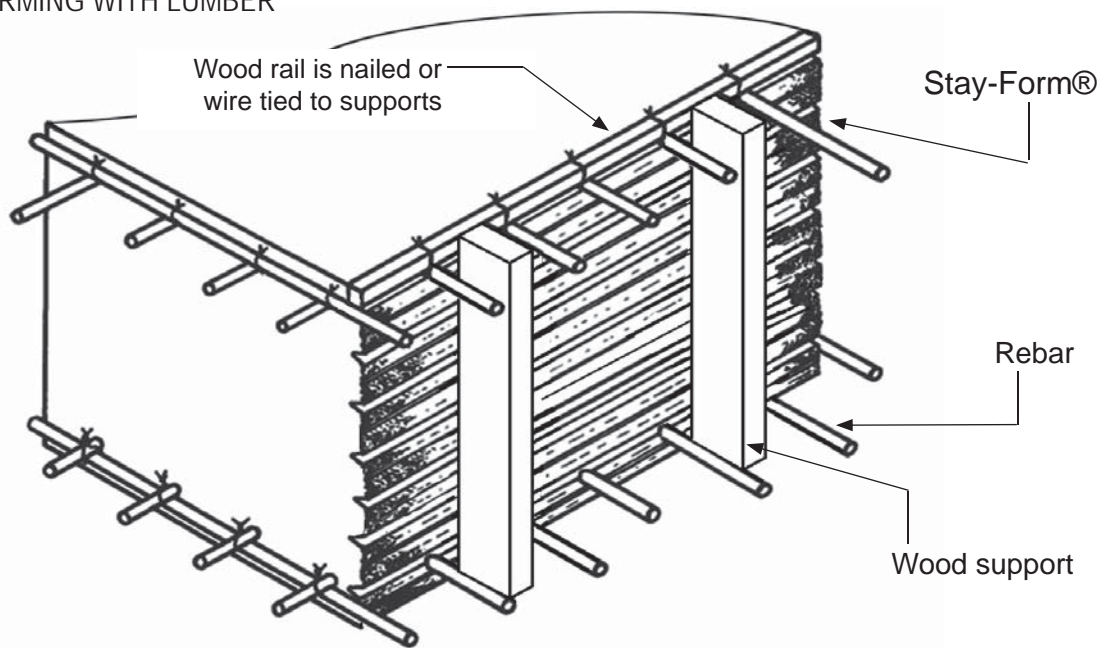

NOTE: See load table on page 3 for spacing and load information.



## FORMING HEAVY MAT BULKHEAD WITH KEYWAY

### KEYWAY FORMED WITH REBAR

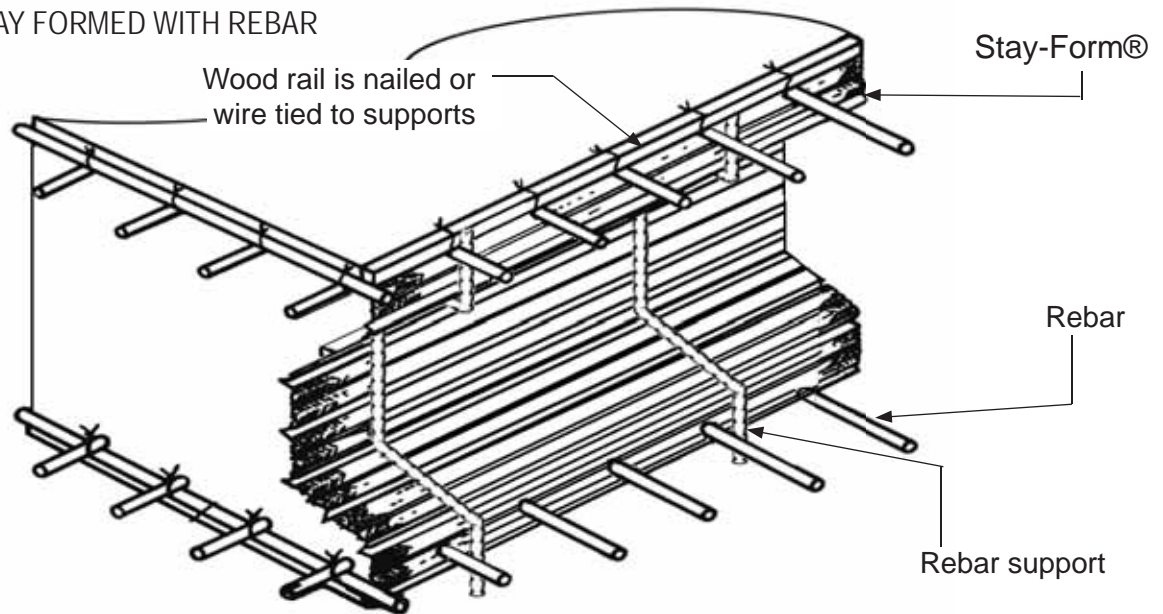

### KEYWAY FORMED WITH LUMBER

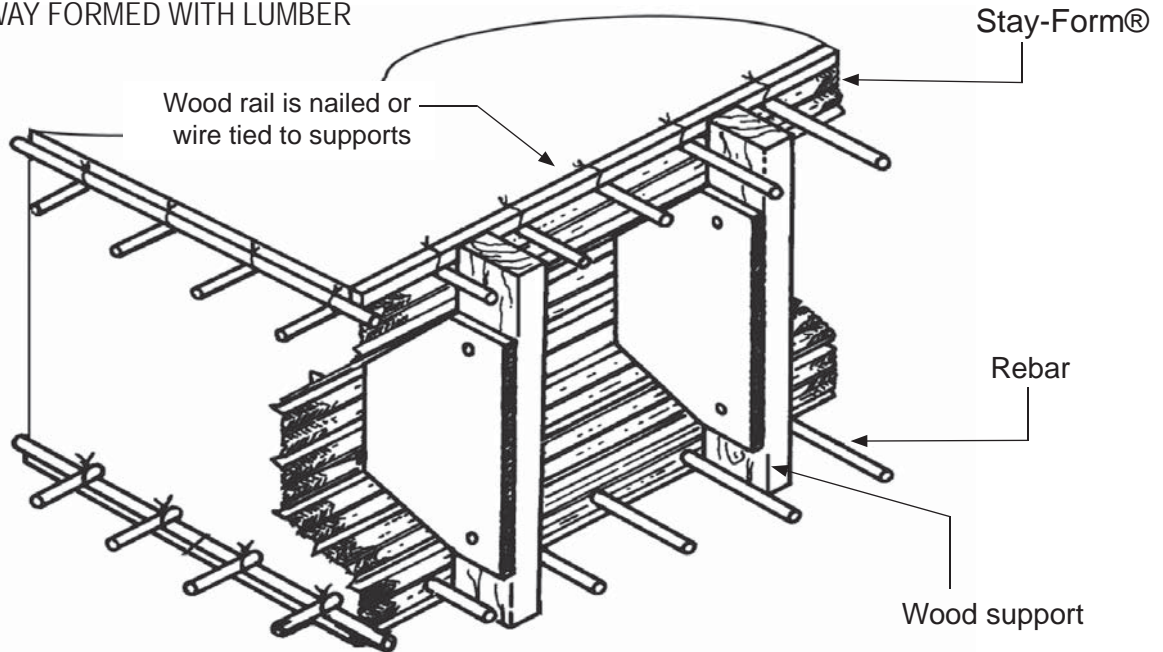

NOTE: See load table on page 3 for spacing and load information.

## FORMING HEAVY MAT BULKHEAD WITH WATERSTOP

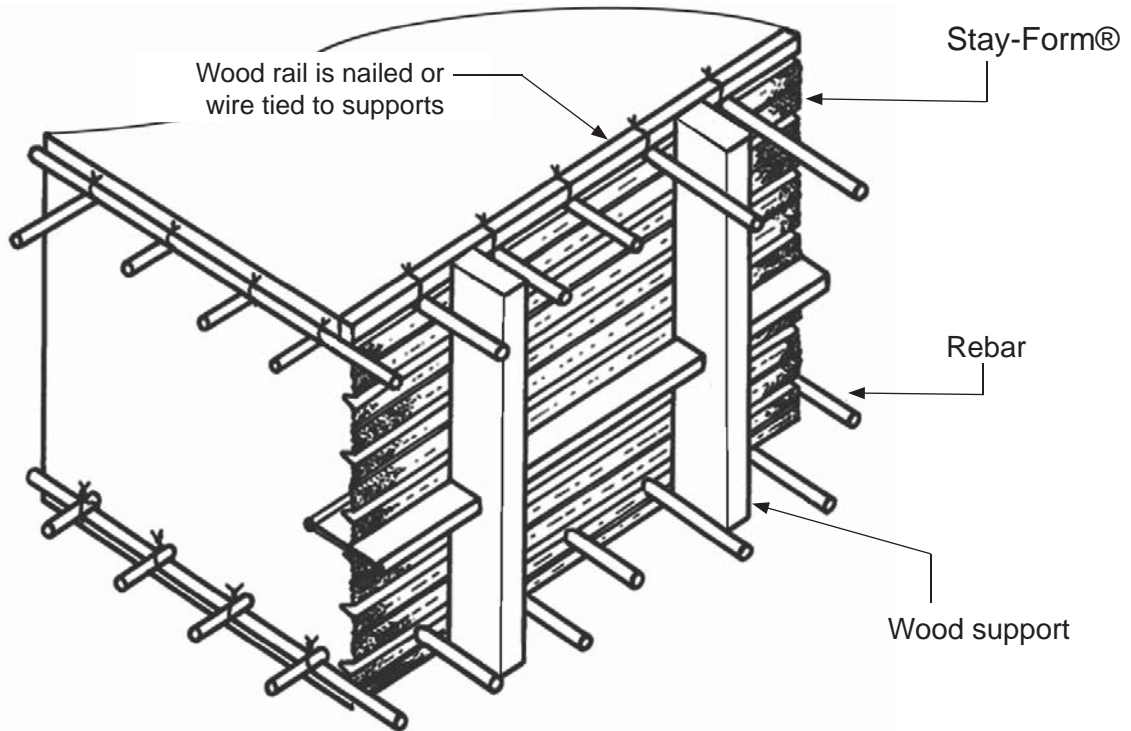

NOTE: See load table on page 3 for spacing and load information.

## FORMING HEAVY MAT BULKHEAD WITH KEYWAY & WATER STOP

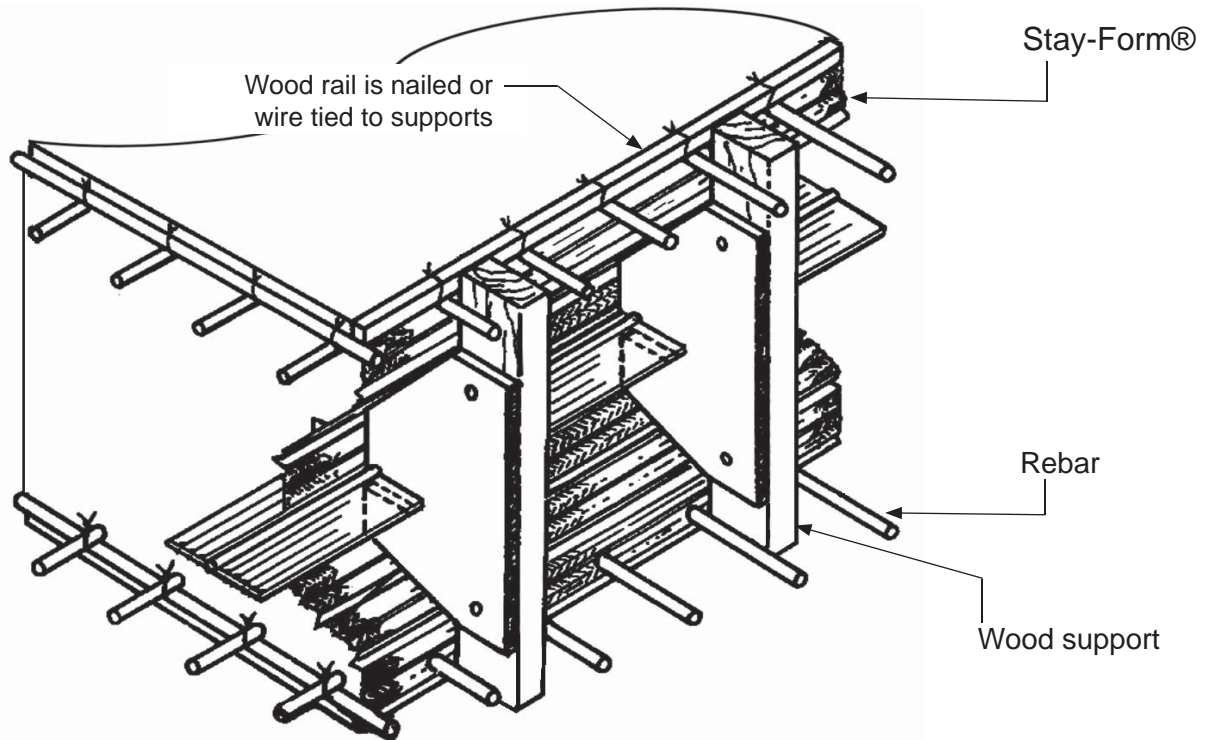

NOTE: See load table on page 3 for spacing and load information.

## FORMING WALL BULKHEAD WITH KEYWAY

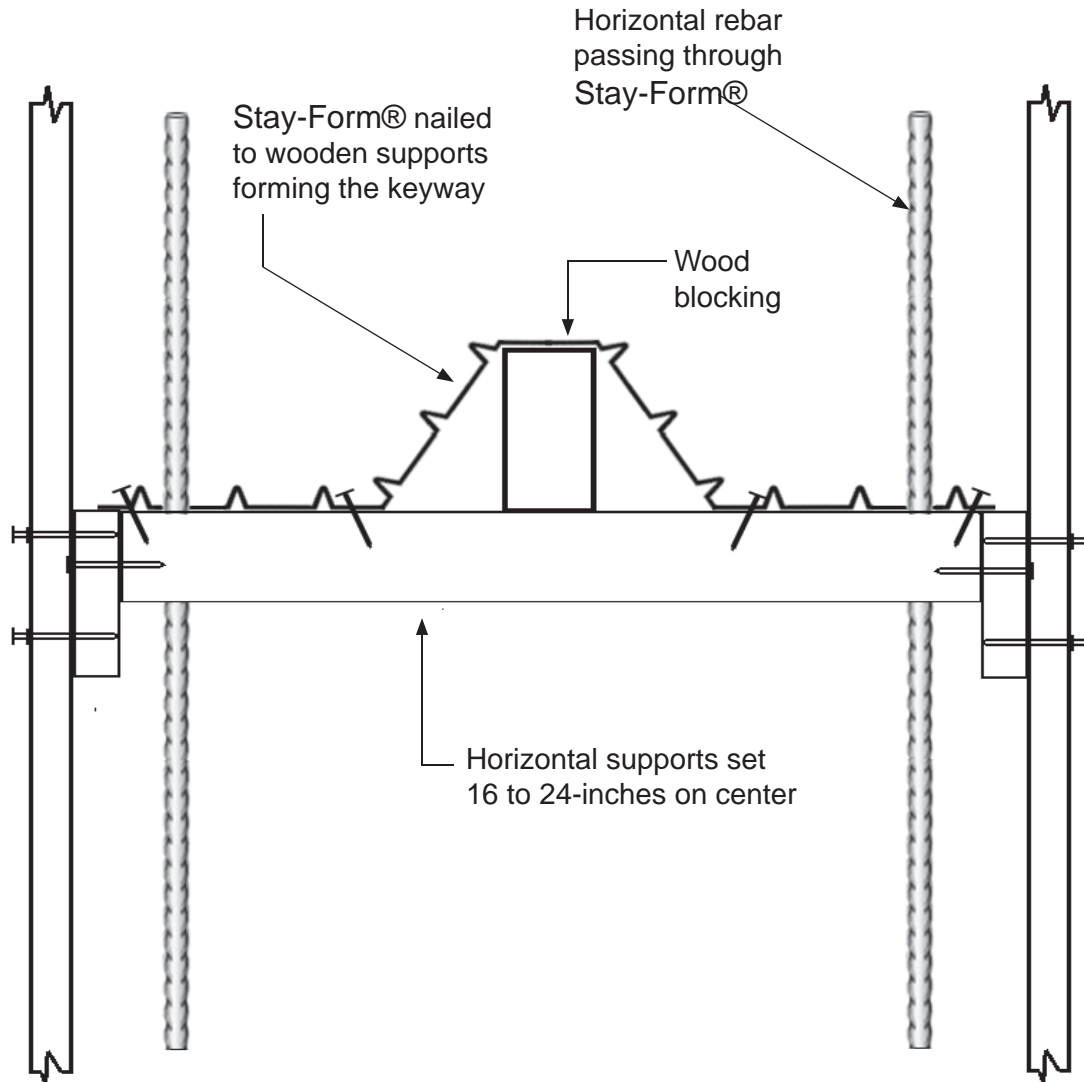

NOTE: See load table on page 3 for spacing and load information.

## FORMING WALL BULKHEAD WITH KEYWAY

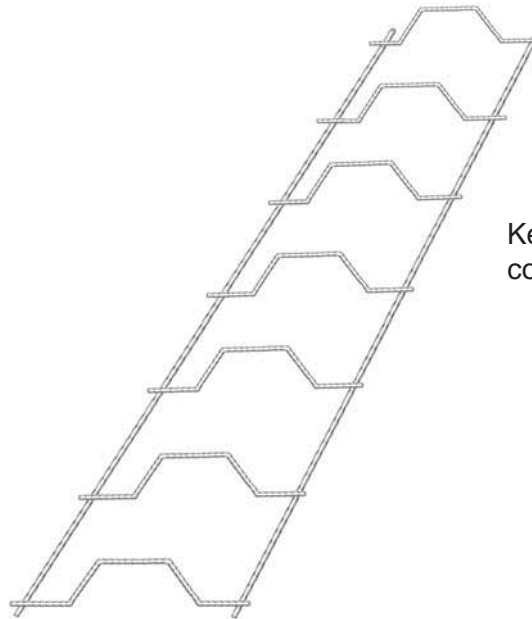
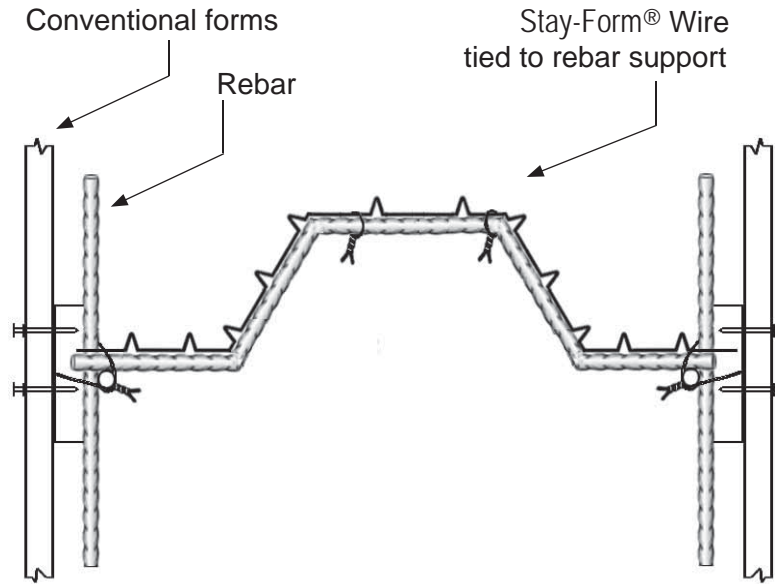

Keyway is fabricated by contractor

NOTE: See load table on page 3 for spacing and load information.



## FORMING WALL BULKHEAD WITH KEYWAY AND WATER STOP (Plan View)

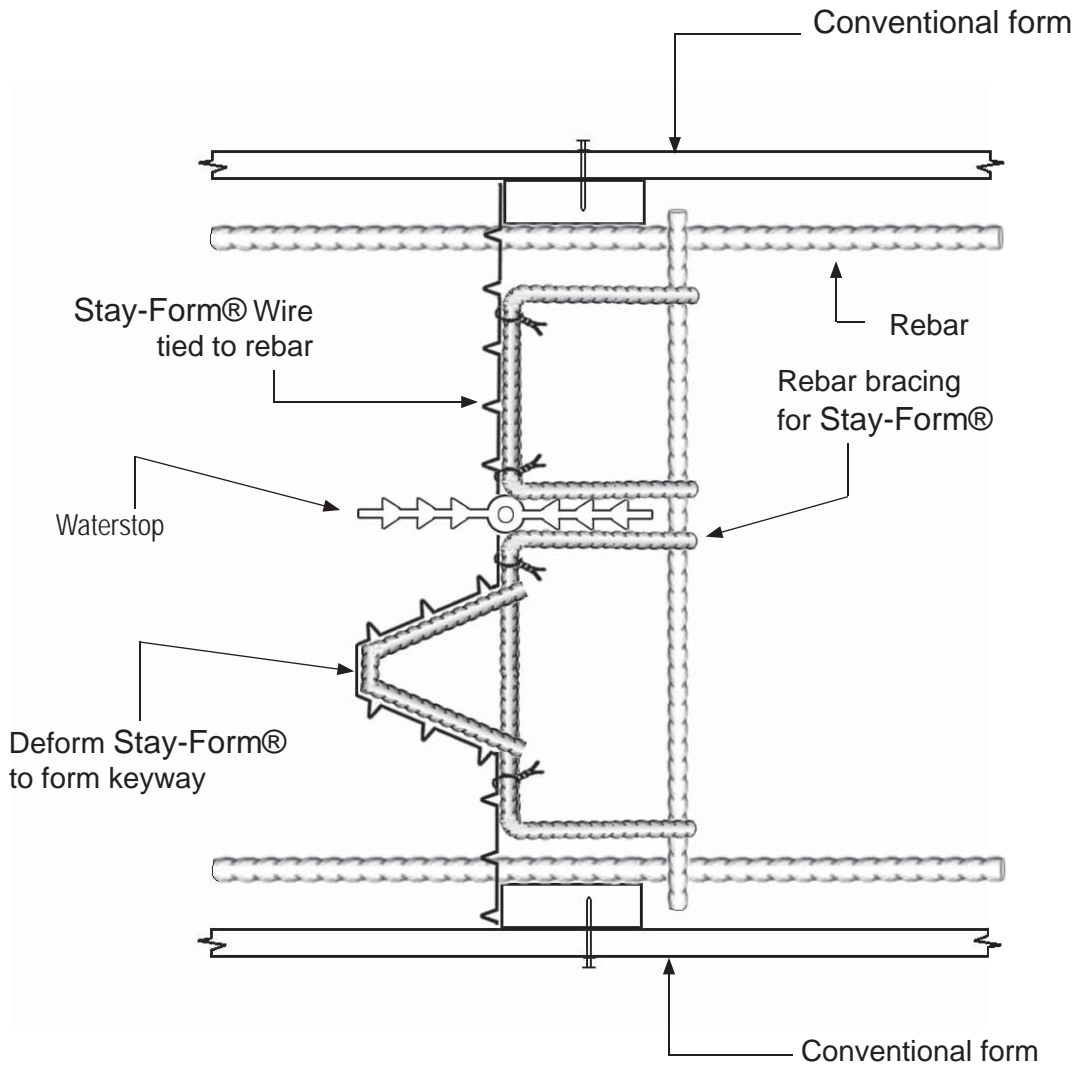

NOTE: See load table on page 3 for spacing and load information.

## FORMING WALL BULKHEAD WITH KEYWAY & WATER STOP (Section View)

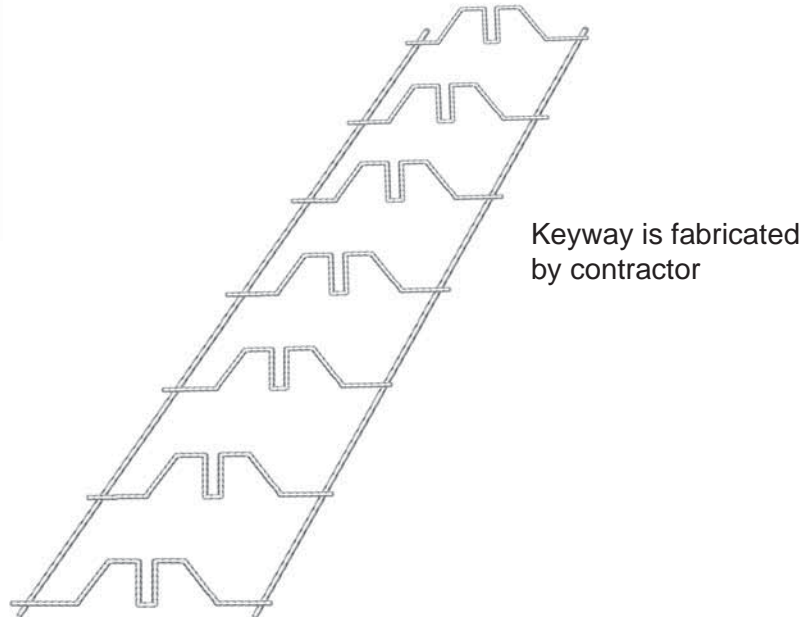
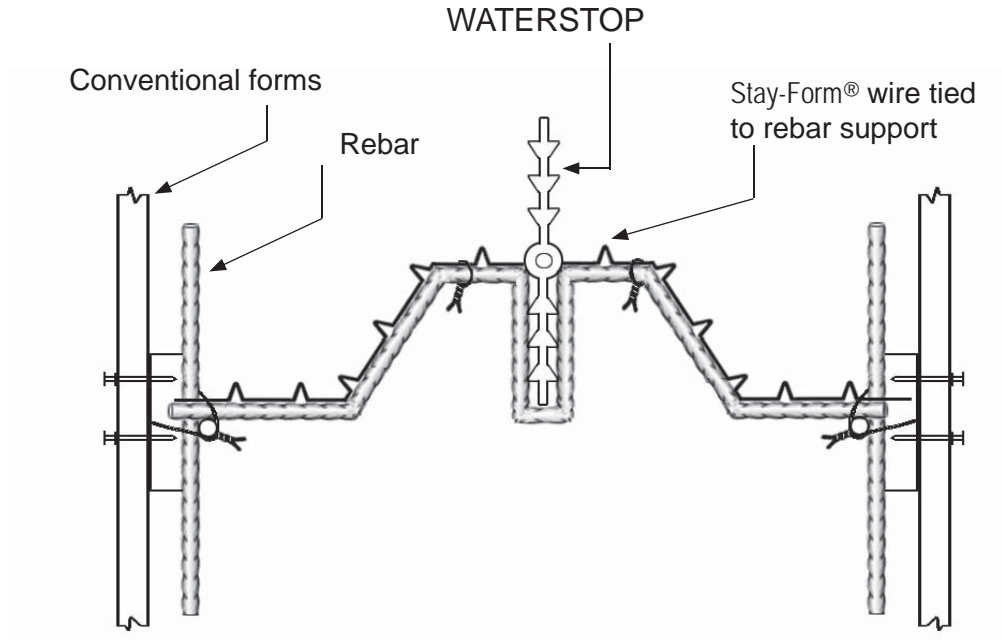

NOTE: See load table on page 3 for spacing and load information.



## FORMING WALL BULKHEAD WITH WATER STOP

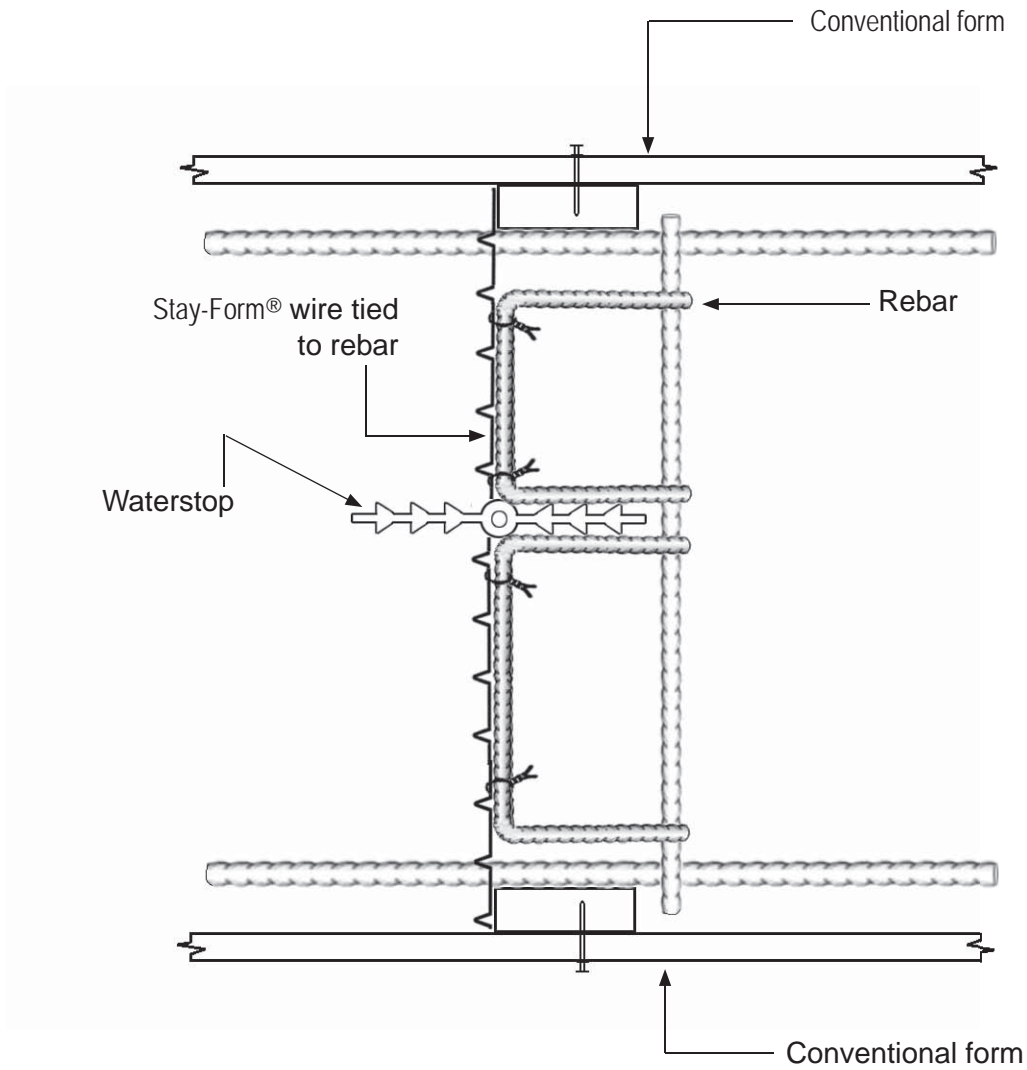

NOTE: See load table on page 3 for spacing and load information.





## BLINDSIDE WALLS

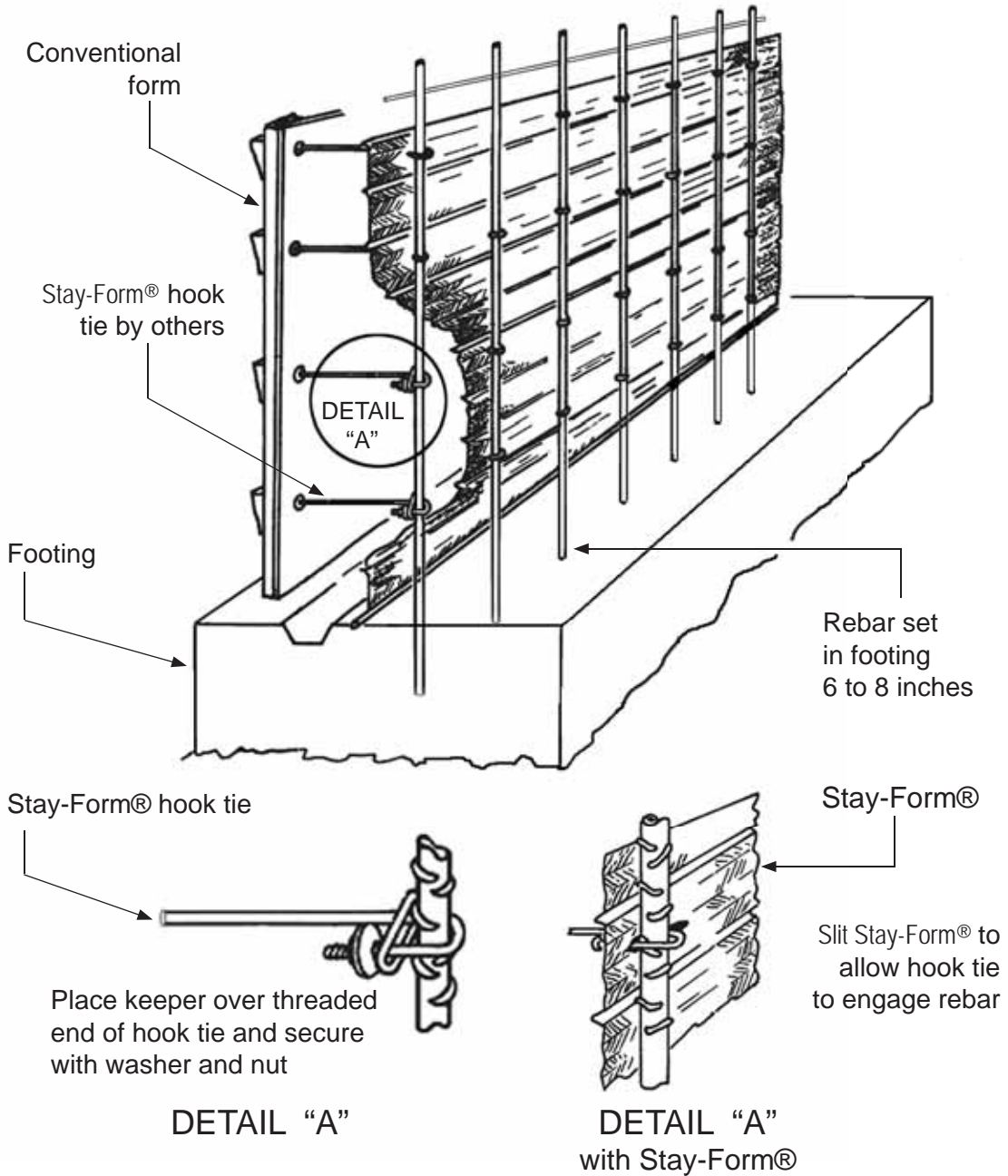

NOTE: See load table on page 3 for spacing and load information.

## FORMING GRADE BEAMS, FOOTINGS AND MAT SLABS

See Note 1 when  
FORMING WITH REBAR

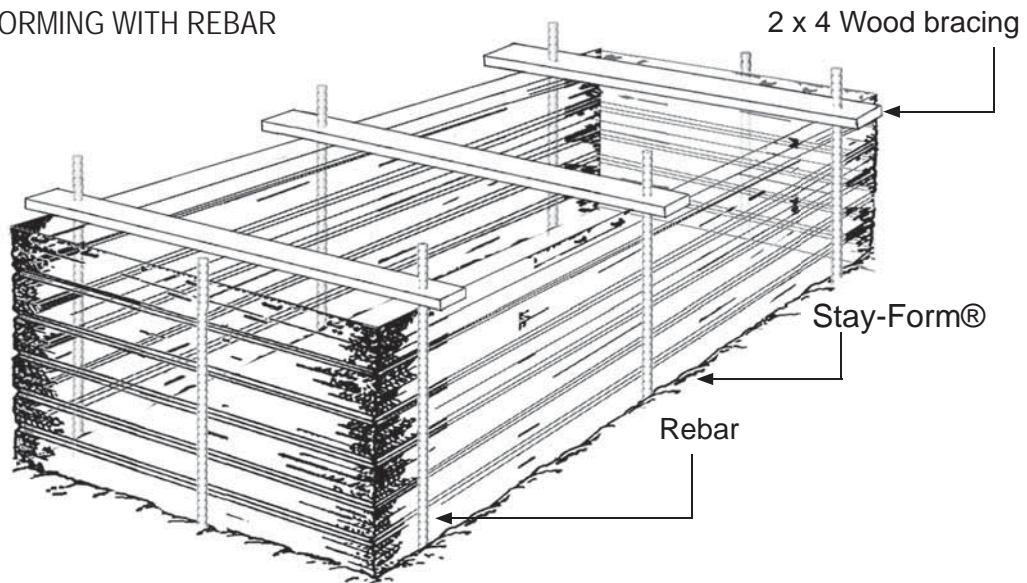

FORMING WITH LUMBER

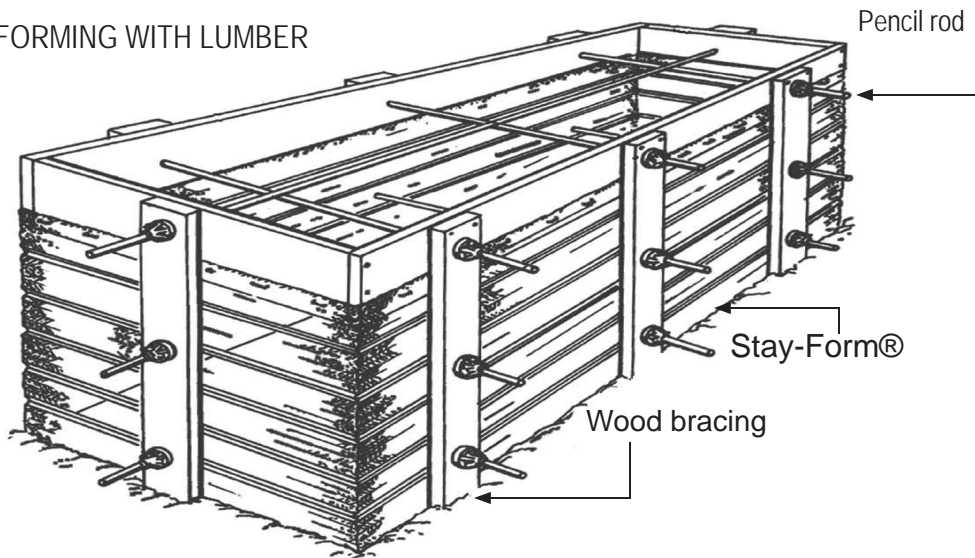

NOTE 1: Horizontal bracing can be accomplished with lumber, tie wire, kickers, pencil rod or by backfilling (90% of form height) prior to the concrete pour.

NOTE: See load table on page 3 for spacing and load information.

## GRADE BEAM FORMWORK

See Note 1 when  
FORMING WITH REBAR

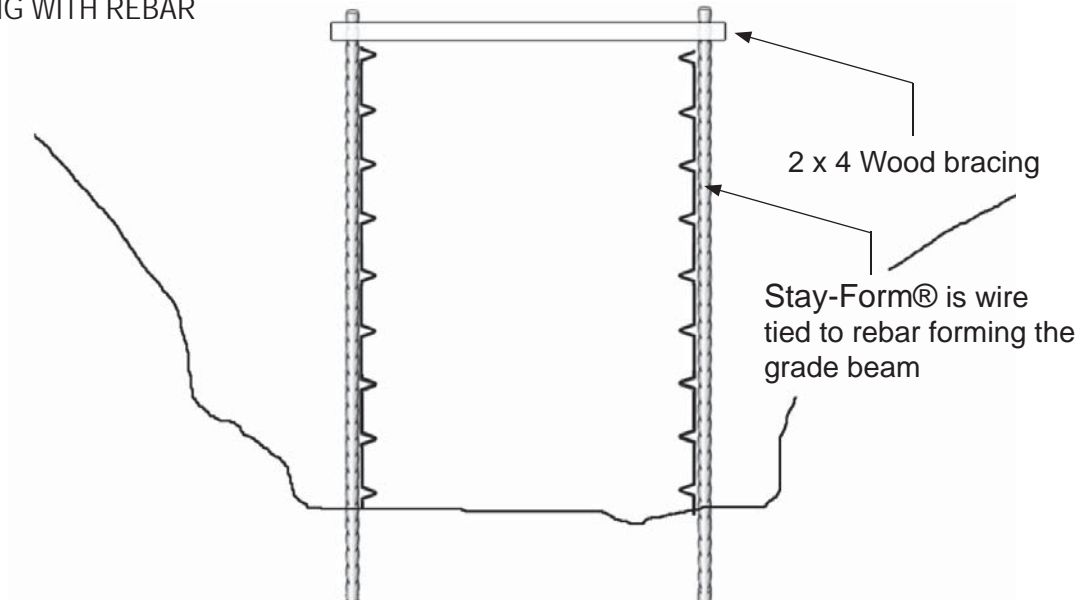

FORMING WITH LUMBER

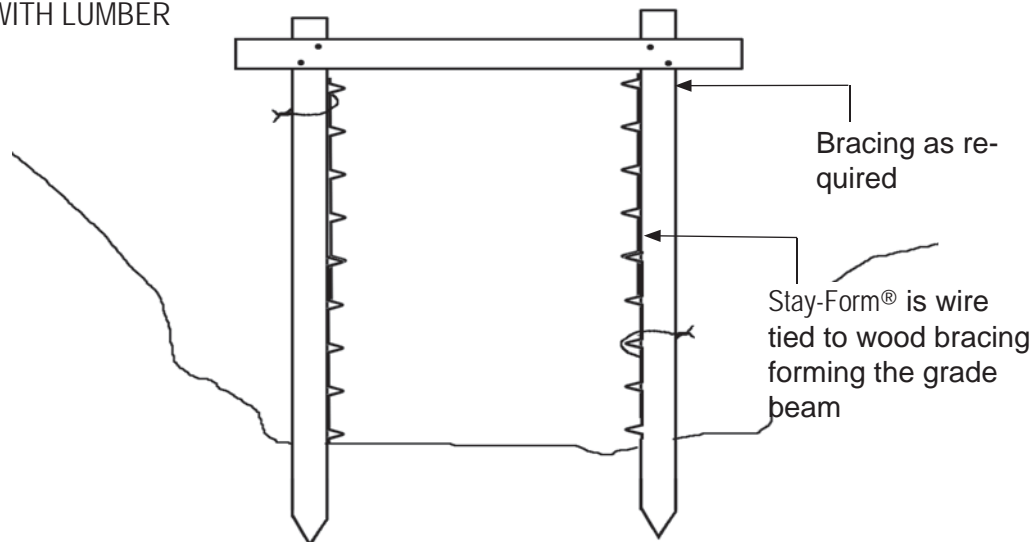

NOTE 1: Horizontal bracing can be accomplished with lumber, tie wire, kickers, pencil rod or by backfilling (90% of form height) prior to the concrete pour.

NOTE: See load table on page 3 for spacing and load information.



## FORMING BLOCK-OUTS WITH REBAR

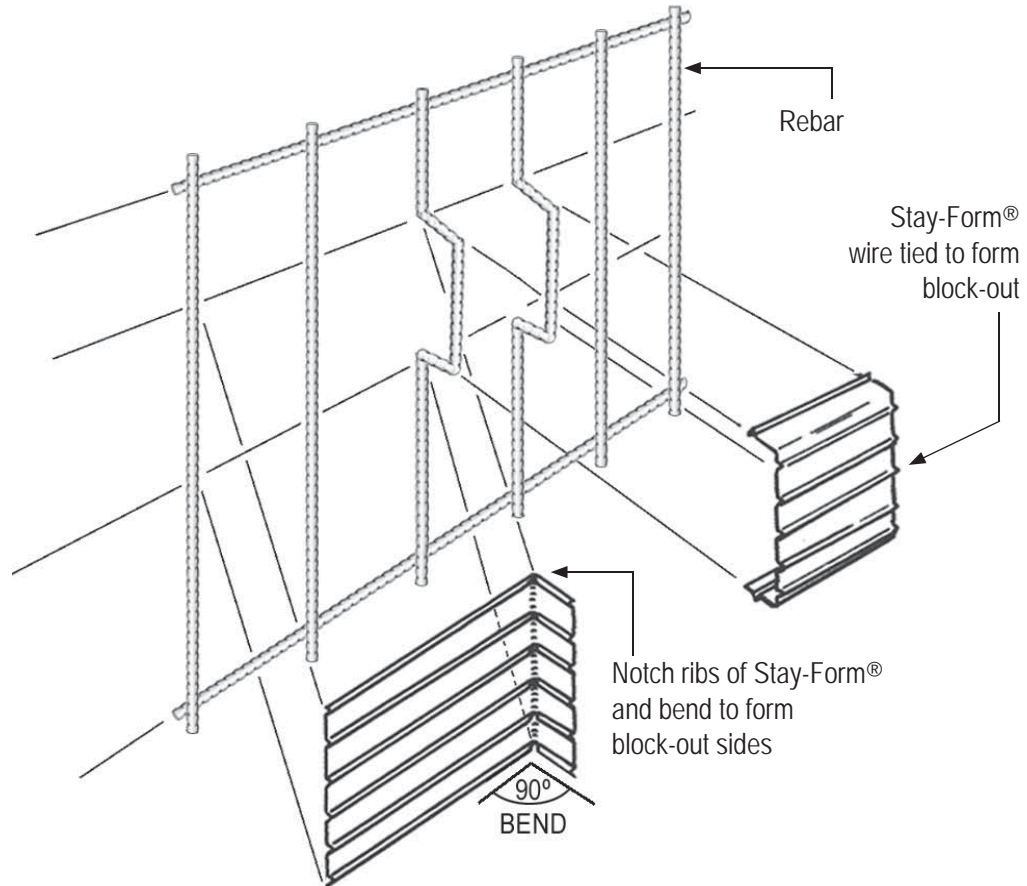

NOTE: See load table on page 3 for spacing and load information.

## FORMING BLOCK-OUTS WITH LUMBER

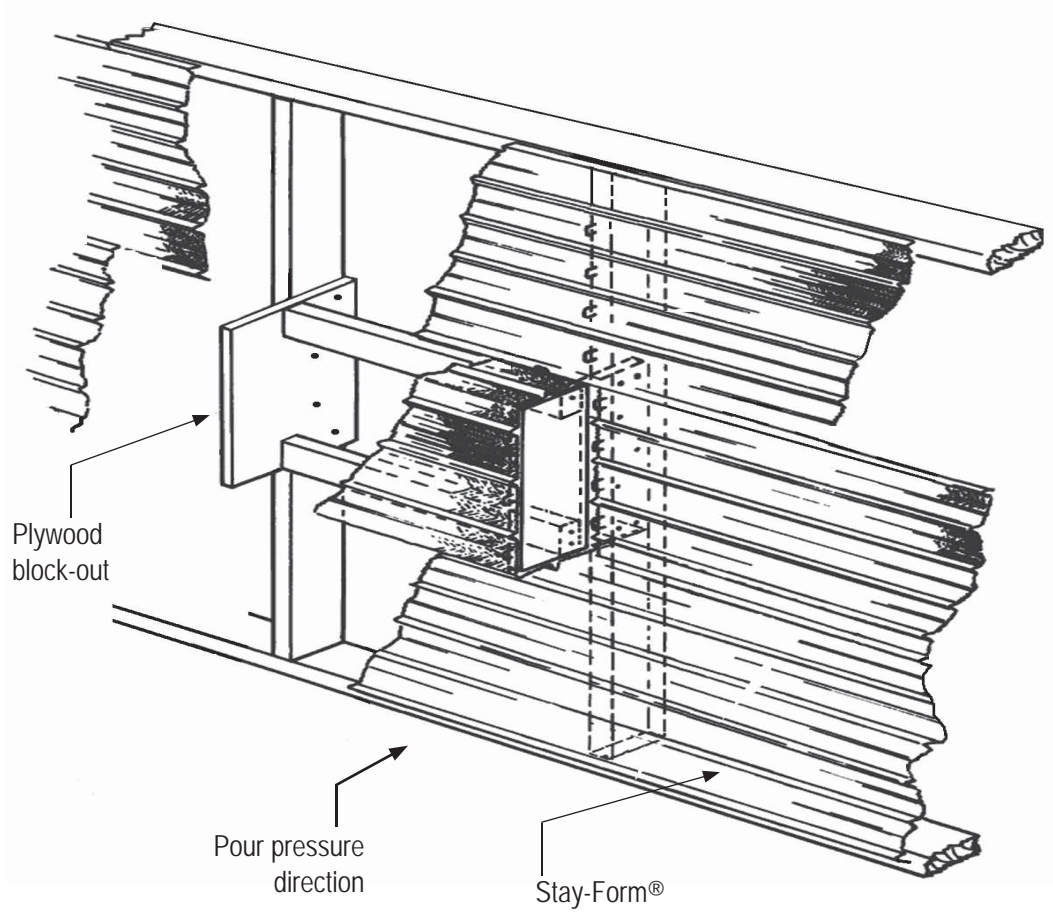

NOTE: See load table on page 3 for spacing and load information.



## FORMING TYPICAL PILE CAPS

See Note 1 when  
FORMING WITH REBAR

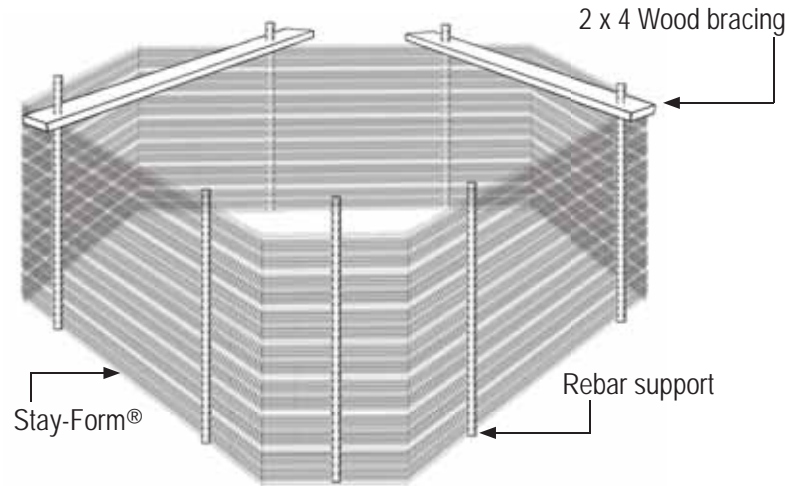

FORMING WITH LUMBER

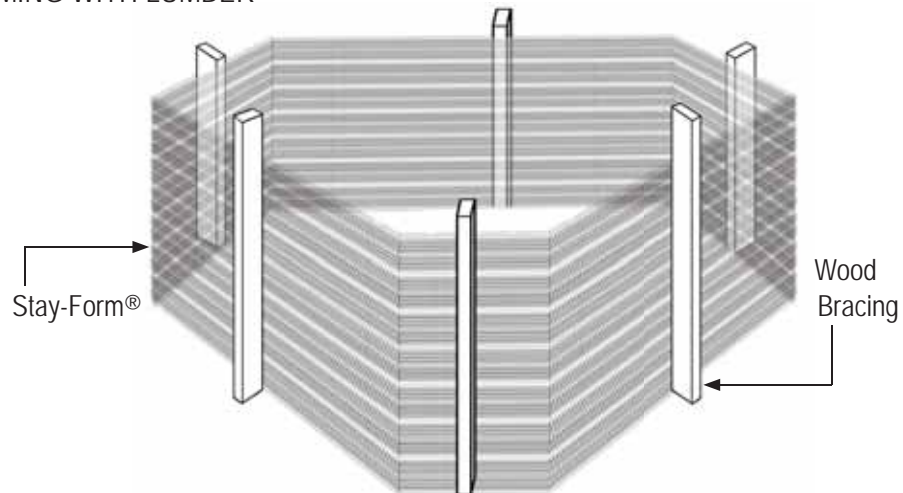

NOTE 1: Horizontal bracing can be accomplished with lumber, tie wire, kickers, pencil rod or by backfilling (90% of form height) prior to the concrete pour.

NOTE: See load table on page 3 for spacing and load information.



## FORMING TYPICAL FOOTINGS

See Note 1 when  
FORMING WITH REBAR

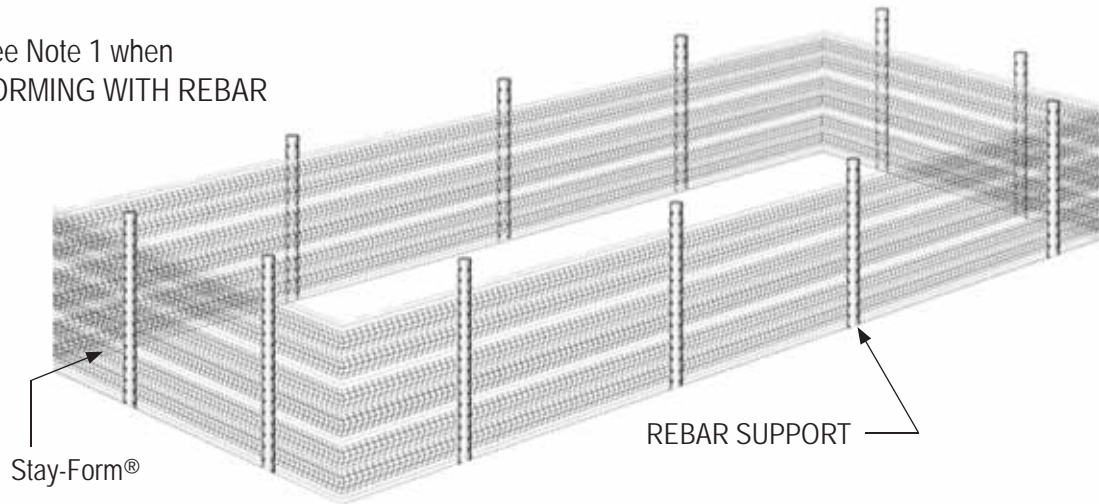

FORMING WITH LUMBER

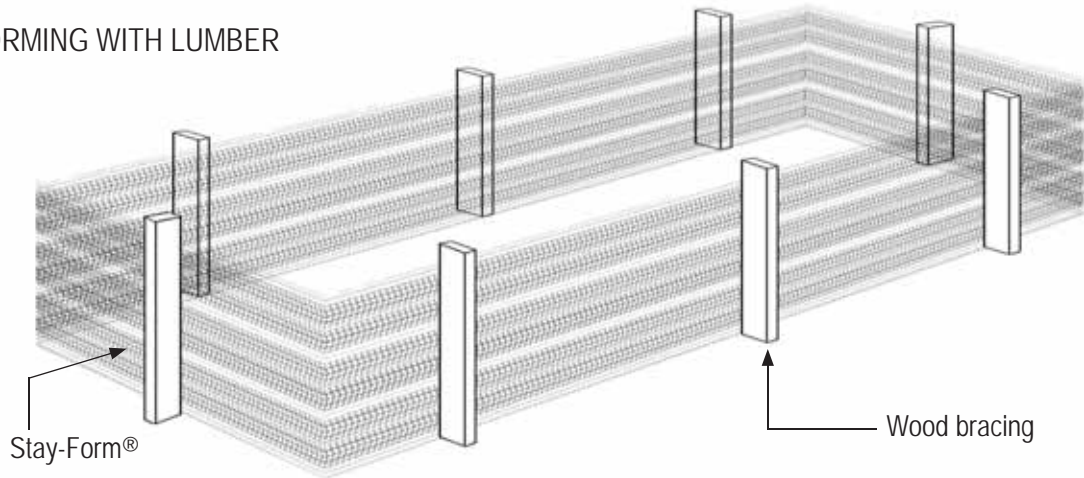

NOTE 1: Horizontal bracing can be accomplished with lumber, tie wire, kickers, pencil rod or by backfilling (90% of form height) prior to the concrete pour.

NOTE: See load table on page 3 for spacing and load information.



## FORMING DUCTBANKS

See Note 1 when  
FORMING WITH REBAR

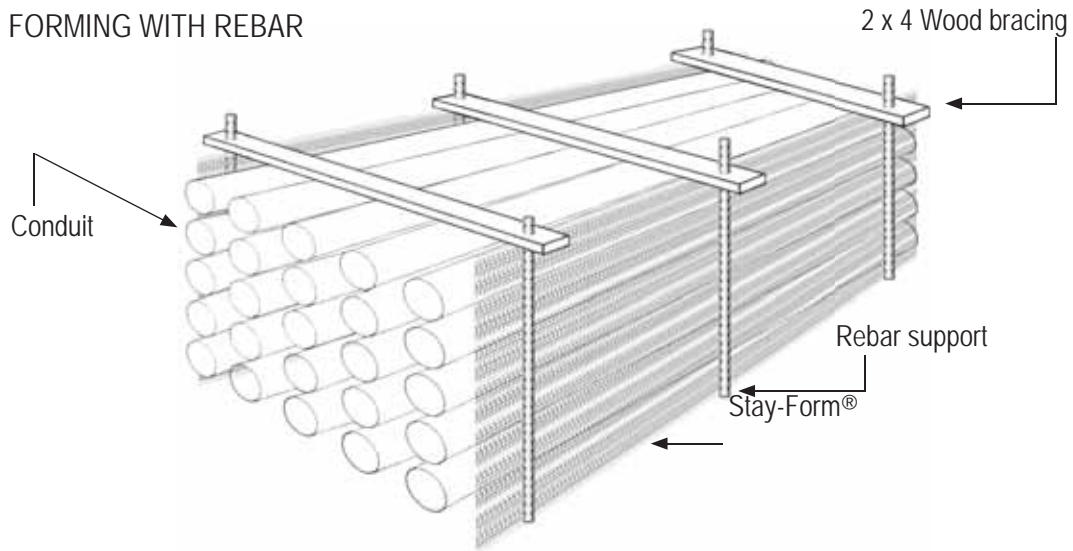

FORMING WITH LUMBER

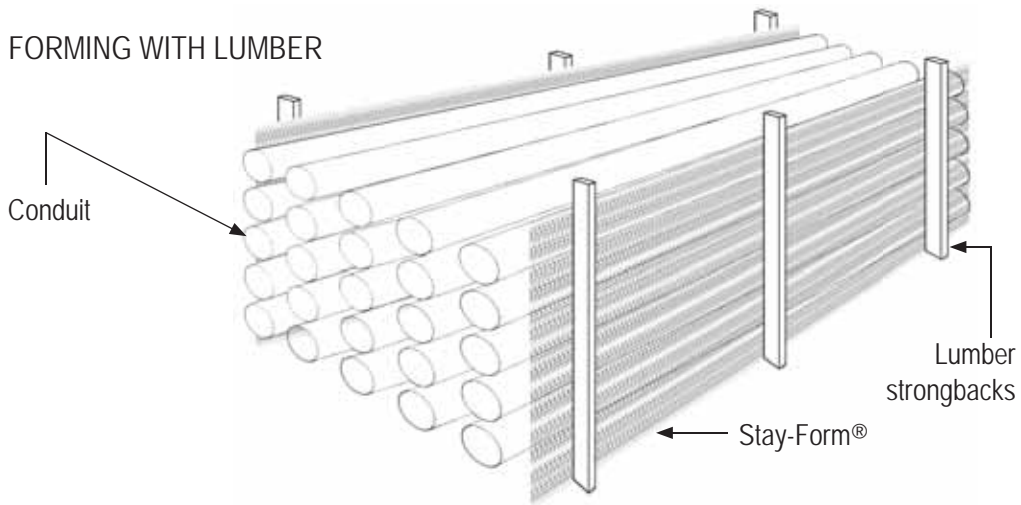

NOTE 1: Horizontal bracing can be accomplished with lumber, tie wire, kickers, pencil rod or by backfilling (90% of form height) prior to the concrete pour.

NOTE: See load table on page 3 for spacing and load information.





## FORMING BEAM WITH KEYWAY

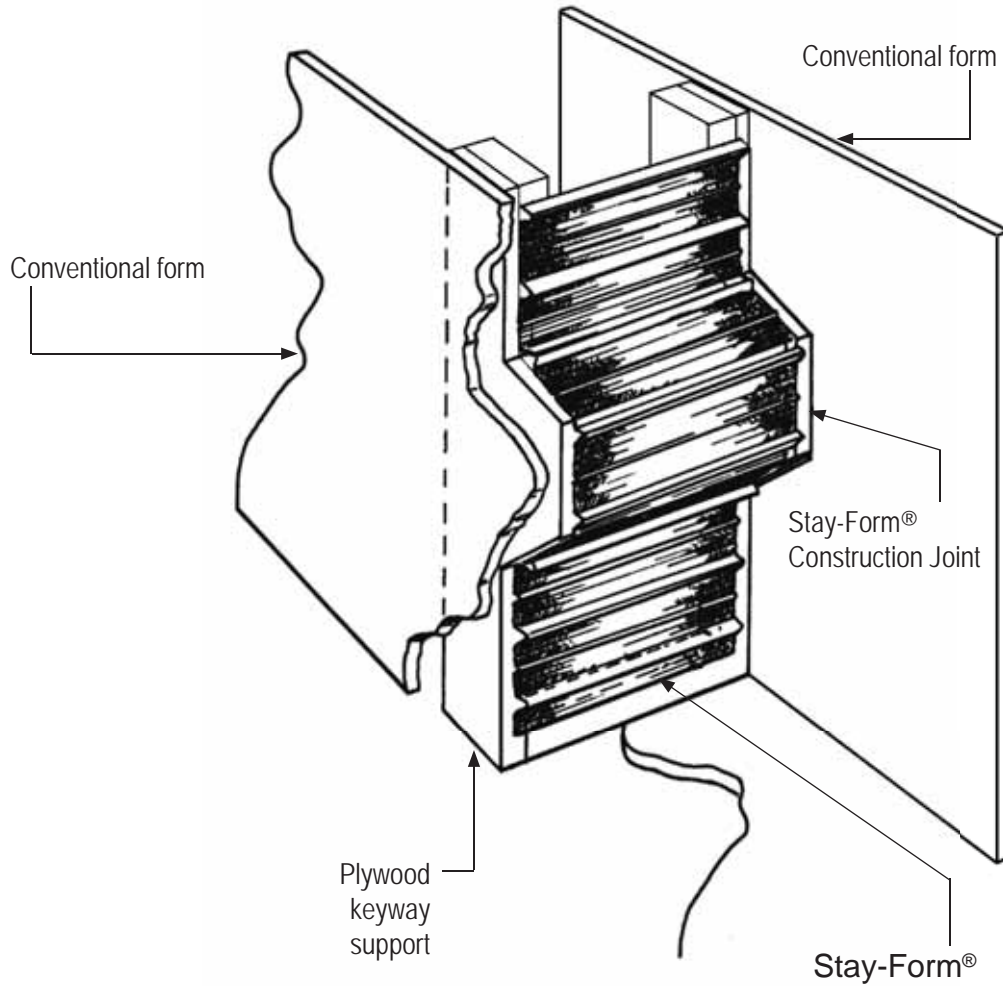

NOTE: See load table on page 3 for spacing and load information.



## FORMING PAN JOIST CONSTRUCTION JOINT

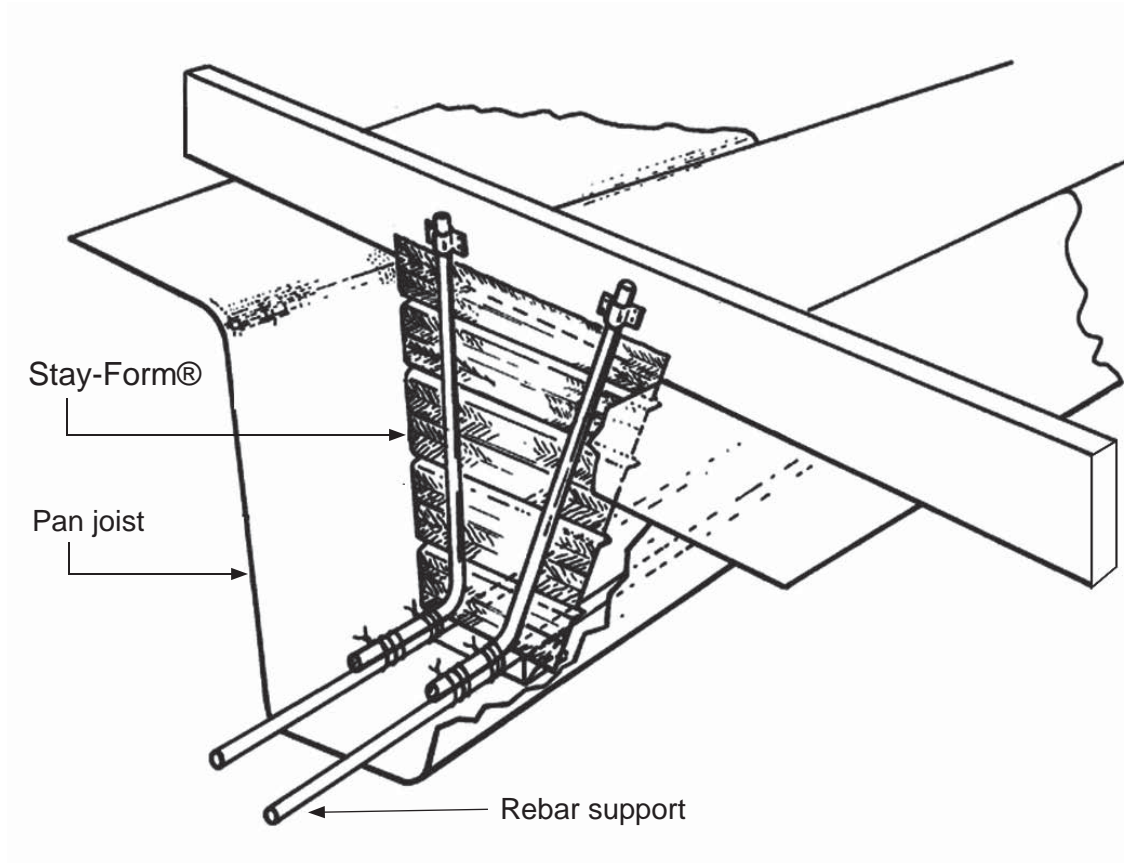

NOTE: See load table on page 3 for spacing and load information.

## FORMING ON GRADE SLOPED SLAB

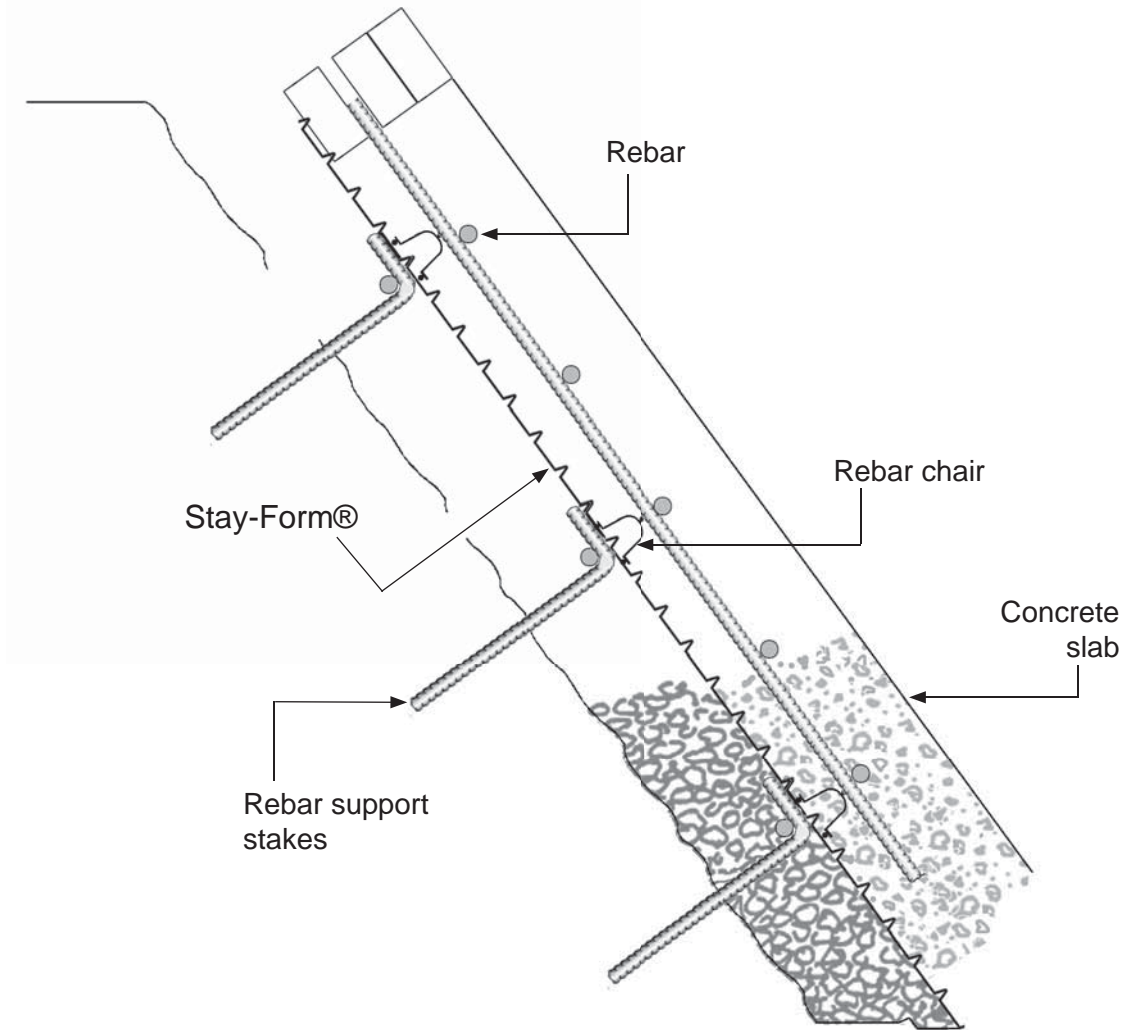

NOTE: Stay-Form may be used in ground stabilization applications using shotcrete or concrete.

NOTE: See load table on page 3 for spacing and load information.

## FORMING BOX BEAM CAVITIES

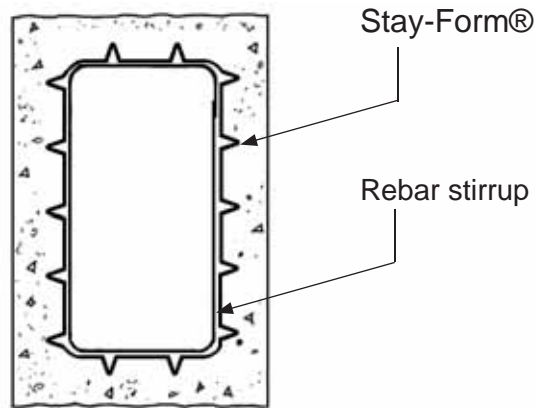
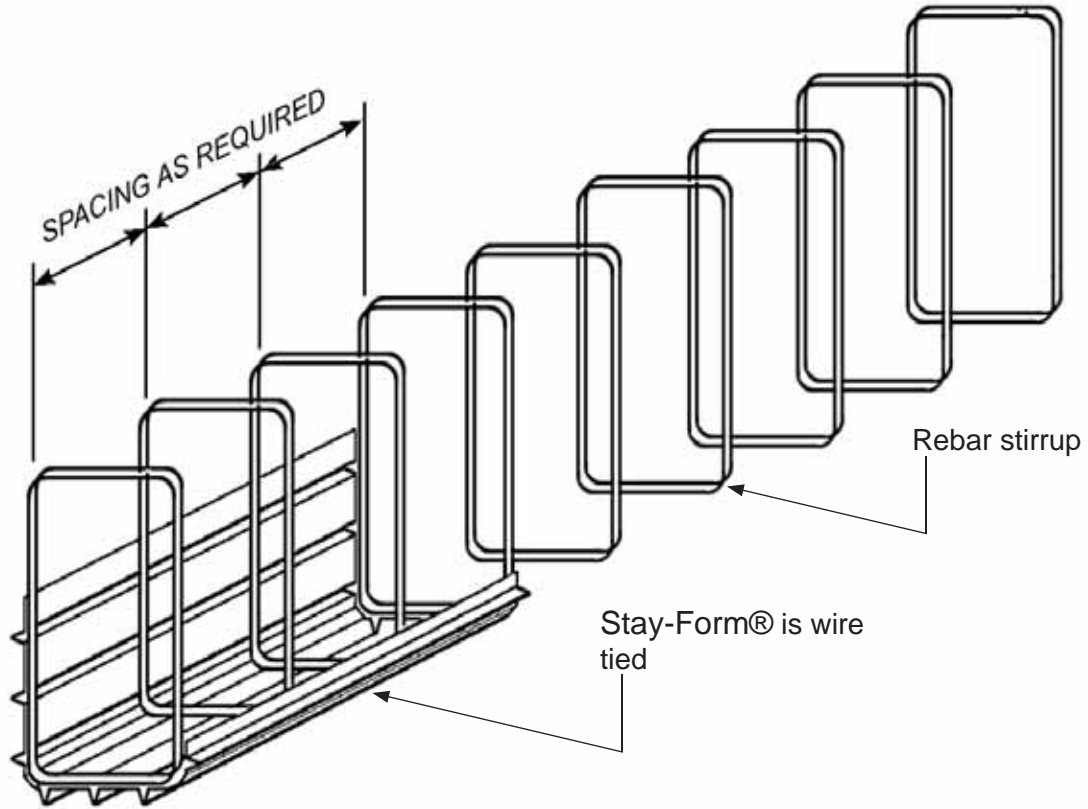

NOTE: See load table on page 3 for spacing and load information.

## FORMING SLAB POCKET

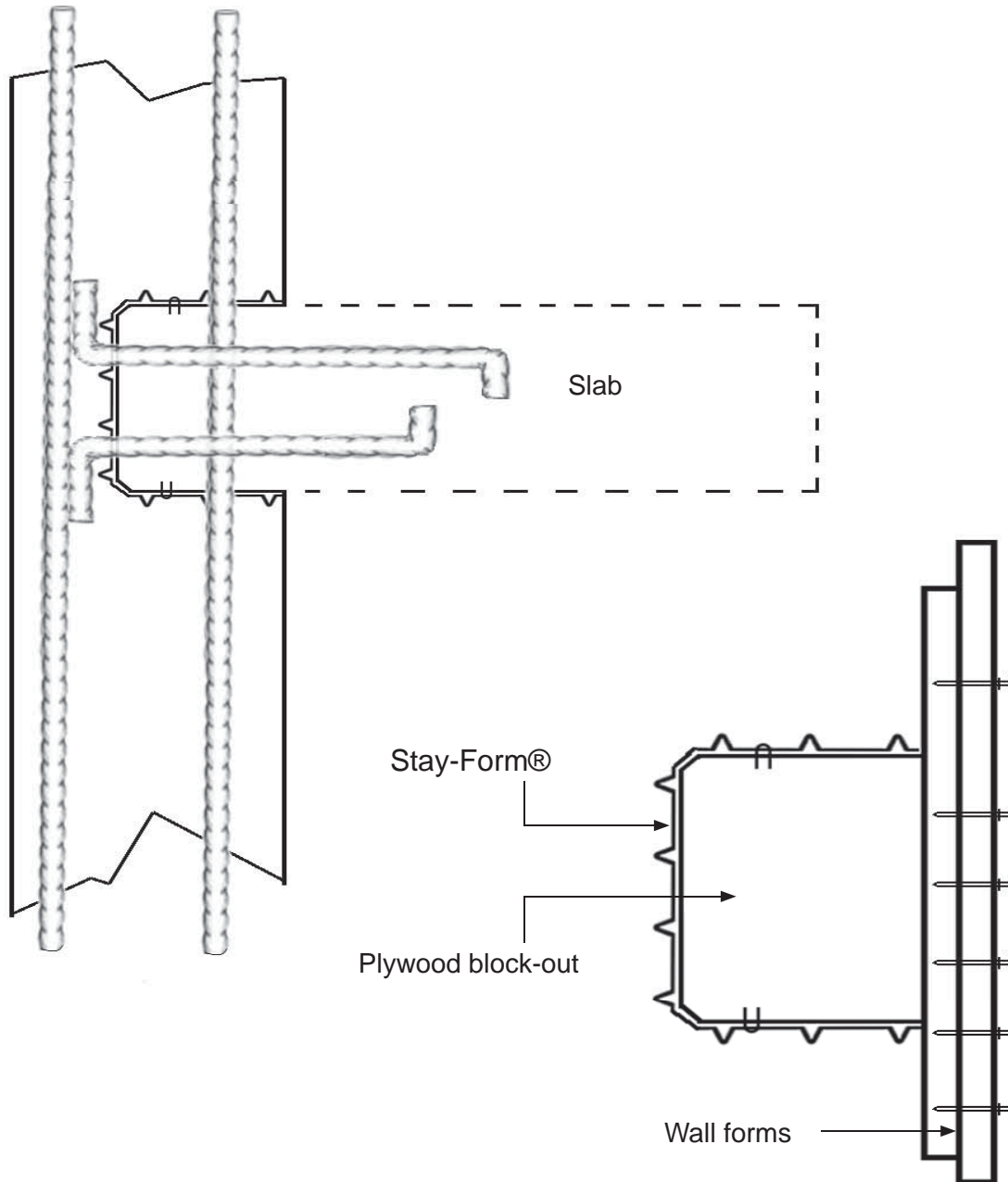

NOTE: See load table on page 3 for spacing and load information.

## FORMING CONCRETE COLUMNS

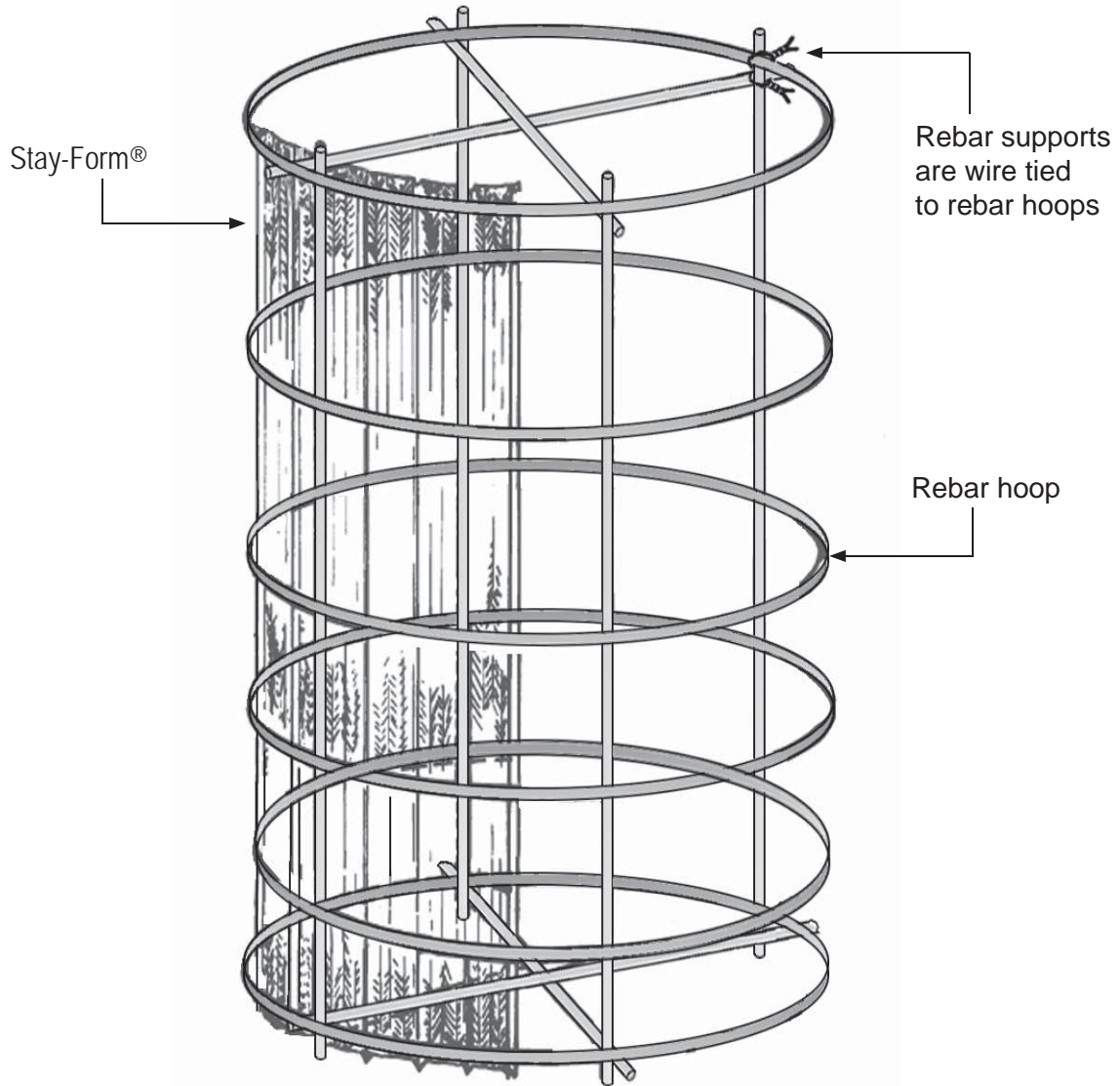

NOTE: See load table on page 3 for spacing and load information.

## UNDER WATER PILING REPAIR

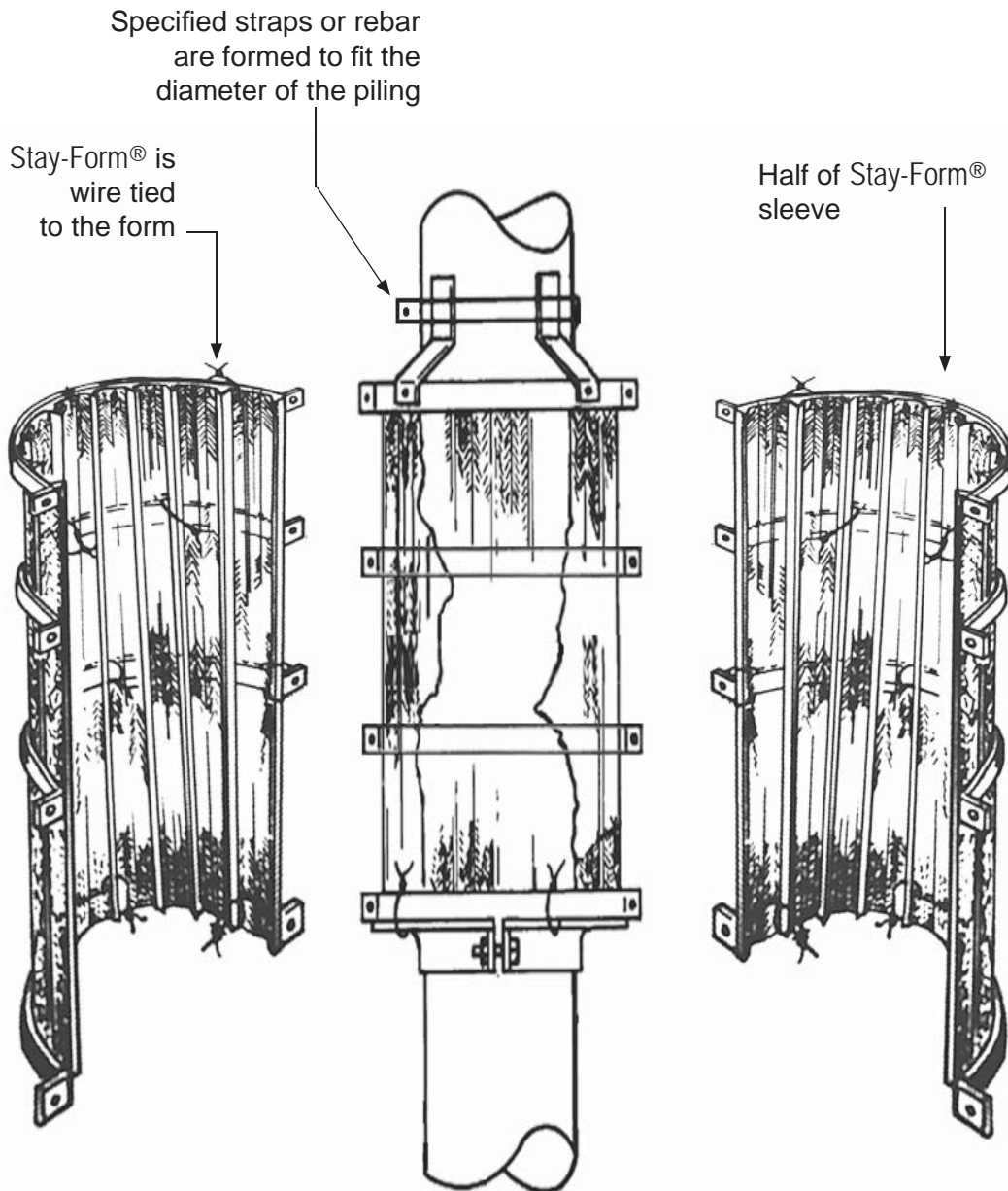

NOTE: See load table on page 3 for spacing and load information.

## FORMING FLOOD WALLS

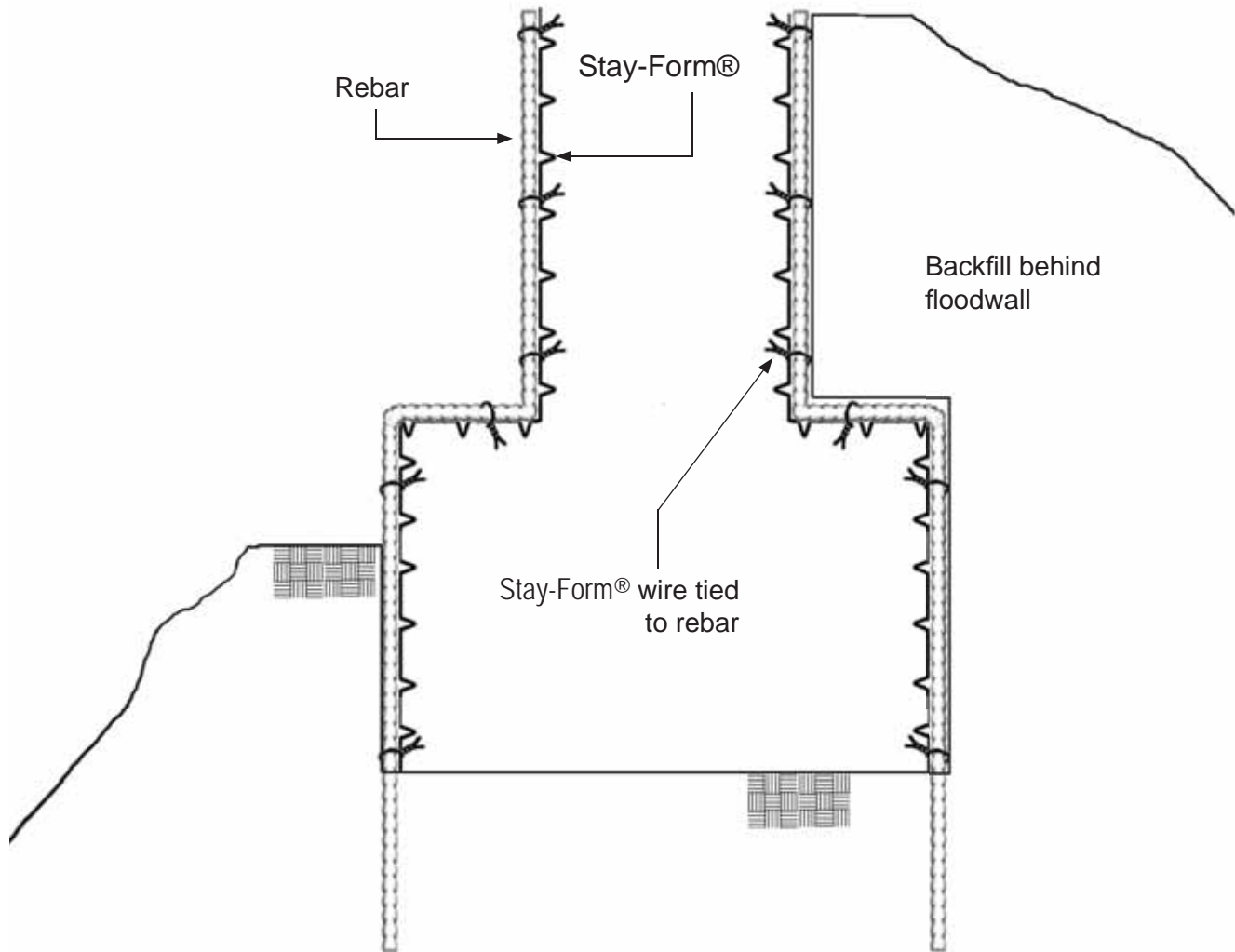

NOTE: See load table on page 3 for spacing and load information.



